

**INSTALLATION NOTES:**

1. USE ONLY WITH DOT-3 OR DOT-4 BRAKE FLUID.
2. NO INTERNAL TRAVEL LIMITER. MUST BE USED WITH CLUTCH PEDAL STOP.
3. SEAL REBUILD KIT = 62-905.
4. SEAL INSTALLATION TOOL = 96-002.
5. HYDRAULIC AREA = 1.215 SQ IN.
6. EITHER PORT MAY BE USED FOR FEED OR BLEED.
7. ORIENTATE BLEED PORT TO WITHIN 10 DEGREES OF TOP CENTER TO FACILITATE BLEEDING PROCESS.
8. UNIT IS SHIPPED WITH 62-903 SHIM (.050" THICK) INSTALLED UNDER THE BEARING WHICH MAY BE REMOVED FOR ADDITIONAL CLEARANCE.
9. BOTH PORTS 3/8-24 UNF X .28 THREAD DEPTH.

ITEM	PART NUMBER	DESCRIPTION	QTY
1	62-617	WIPER	1
2	SEE CHART	PISTON	1
3	62-614	HYDRAULIC SEAL	1
4	62-031	BEARING	1
5	73-820	FITTING, AN-3	2
6	62-806	HYDRAULIC BASE	1
7	62-903	SHIM	1

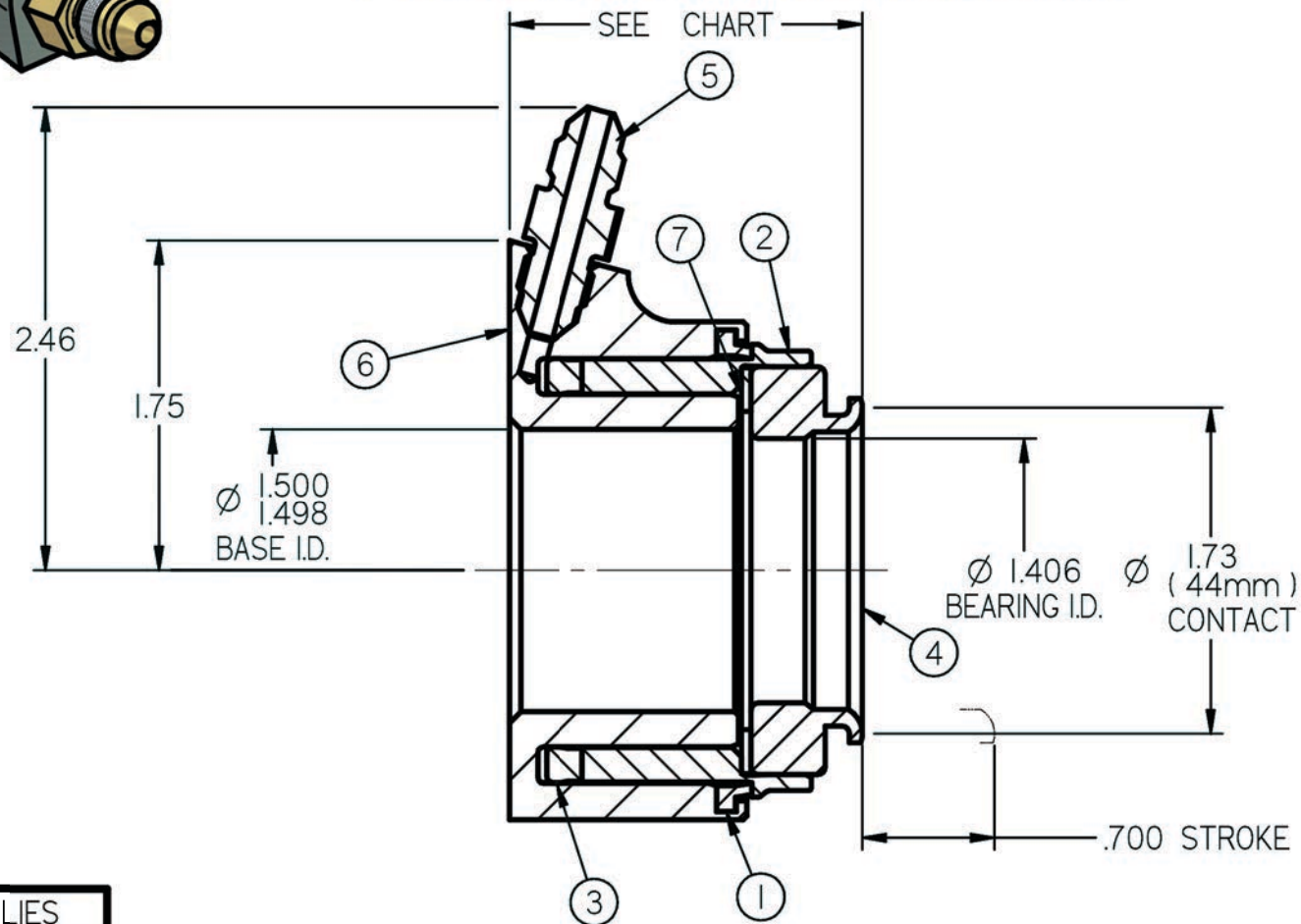

SECTION A-A

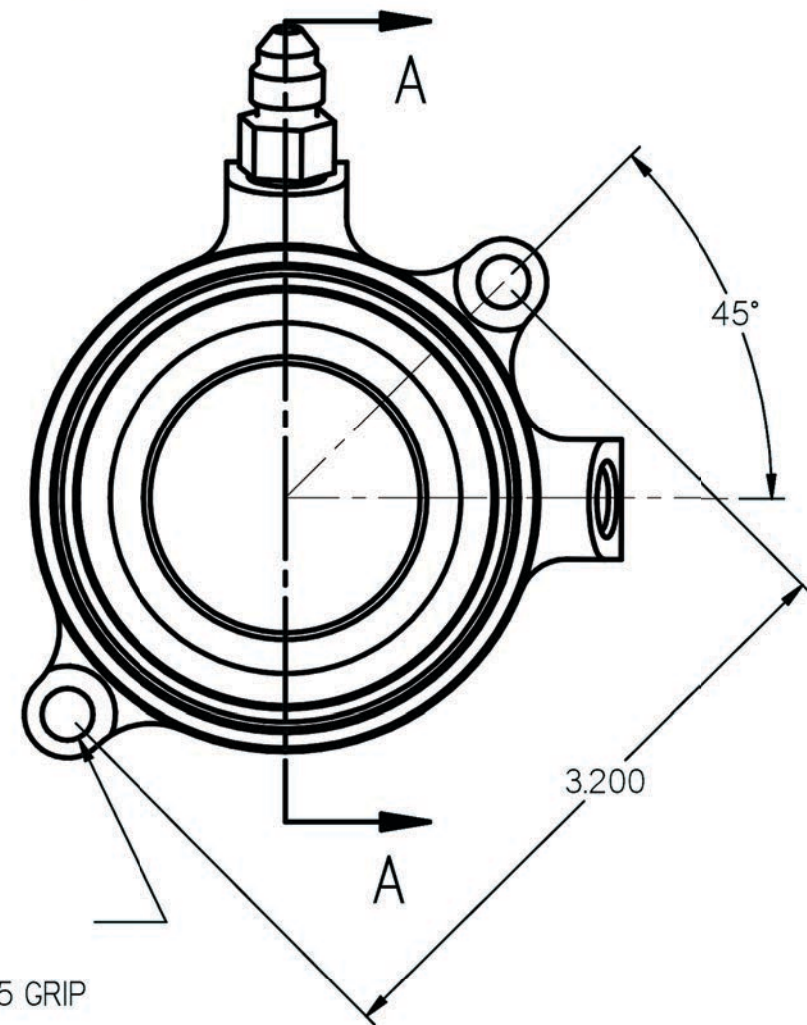

Ø .266 THRU HOLES  
SUITABLE FOR 1/4"  
OR 6mm FASTENERS, .15 GRIP

HEIGHT	ASSY PN	PISTON PN
1.82"-1.87"	60-8200	62-6000
1.92"-1.97"	60-8210	62-6001
2.02"-2.07"	60-8220	62-6002
2.12"-2.17"	60-8230	62-6003
2.22"-2.27"	60-8240	62-6004
2.32"-2.37"	60-8250	62-6005
2.42"-2.47"	60-8260	62-6006
2.52"-2.57"	60-8270	62-6007
2.62"-2.67"	60-8280	62-6008
2.72"-2.77"	60-8290	62-6009

\*HEIGHTS SHOWN IN CHART ARE WITH AND WITHOUT 62-903 SHIM

**TILTON ENGINEERING, INC.**

FAX 805/688-2745

25 EASY STREET, P.O. BOX 1787, BUELLTON, CA 93427 805/688-2353

**TITLE: HYDRAULIC RELEASE BEARING ASSEMBLY  
44 mm RADIUS FACED BEARING, UNIVERSAL BASE**

DRAWN BY WAHL	CHKD LUND	SCALE 1:1	SIZE B	DWG 5598	REV NC
P/N SEE CHART	DATE 03/16/2012	SHEET 1 OF 1			

This document contains proprietary information of TILTON ENGINEERING, INC., and its receipt or possession does not convey the rights to reproduce, disclose its contents, or to manufacture, use or sell anything it may describe. Reproduction, disclosure, or use without specific written authorization of TILTON ENGINEERING, INC. is strictly forbidden.

