

ZONE	CHK'D	DATE	REV	ECN	CHANGE OR ADDITION
ALL	LUND	10/4/2013	A	1102	ADDED DUAL DIMENSIONS

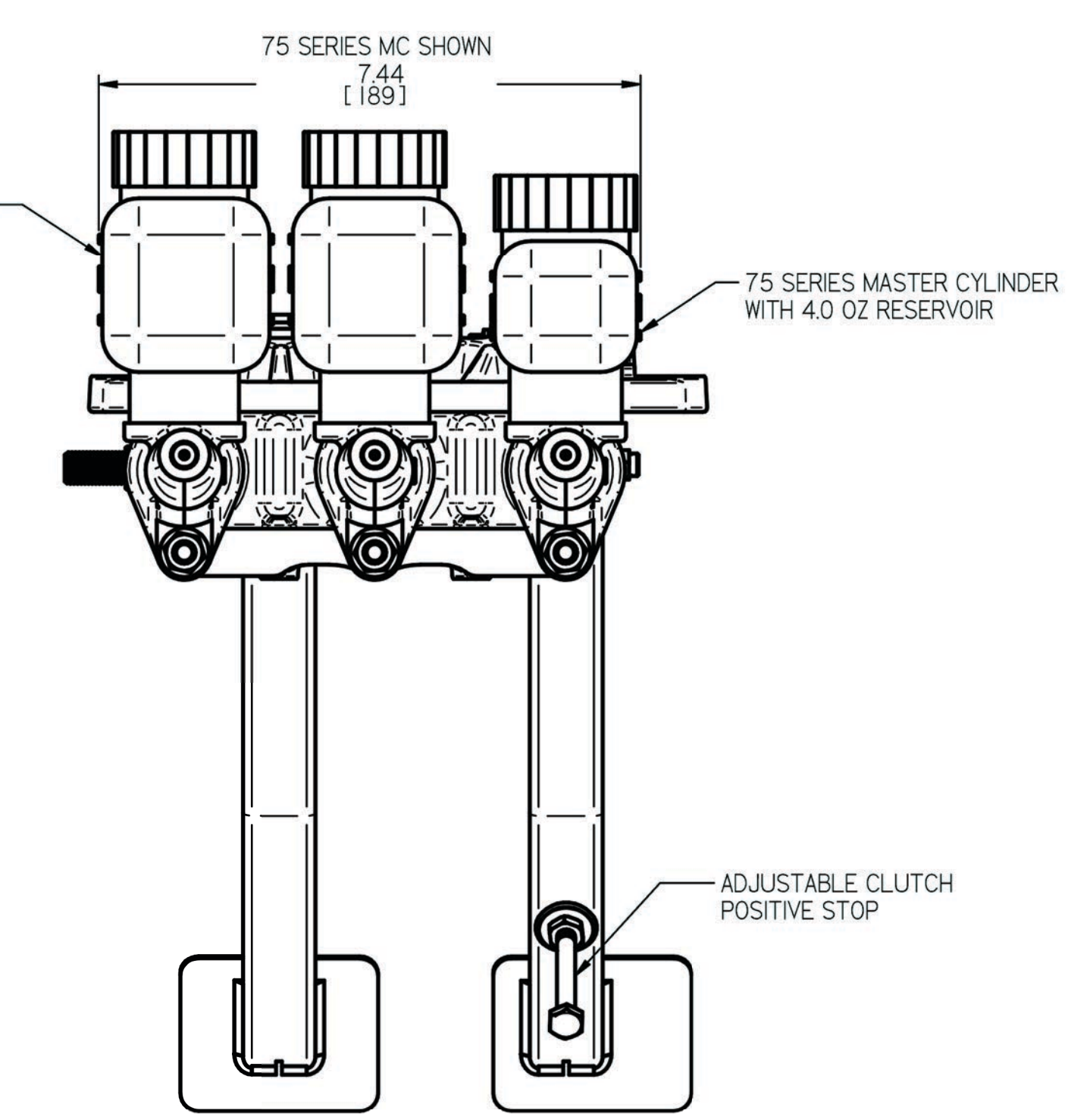

PEDAL ASSEMBLY IS COMPATIBLE WITH TILTON ENGINEERING 73, 74, 75 AND 76 SERIES MASTER CYLINDERS, SOLD SEPARATELY.

75 SERIES MASTER CYLINDERS SHOWN HERE ARE FOR ILLUSTRATION PURPOSES AND ARE NOT INCLUDED WITH PEDAL ASSEMBLY.

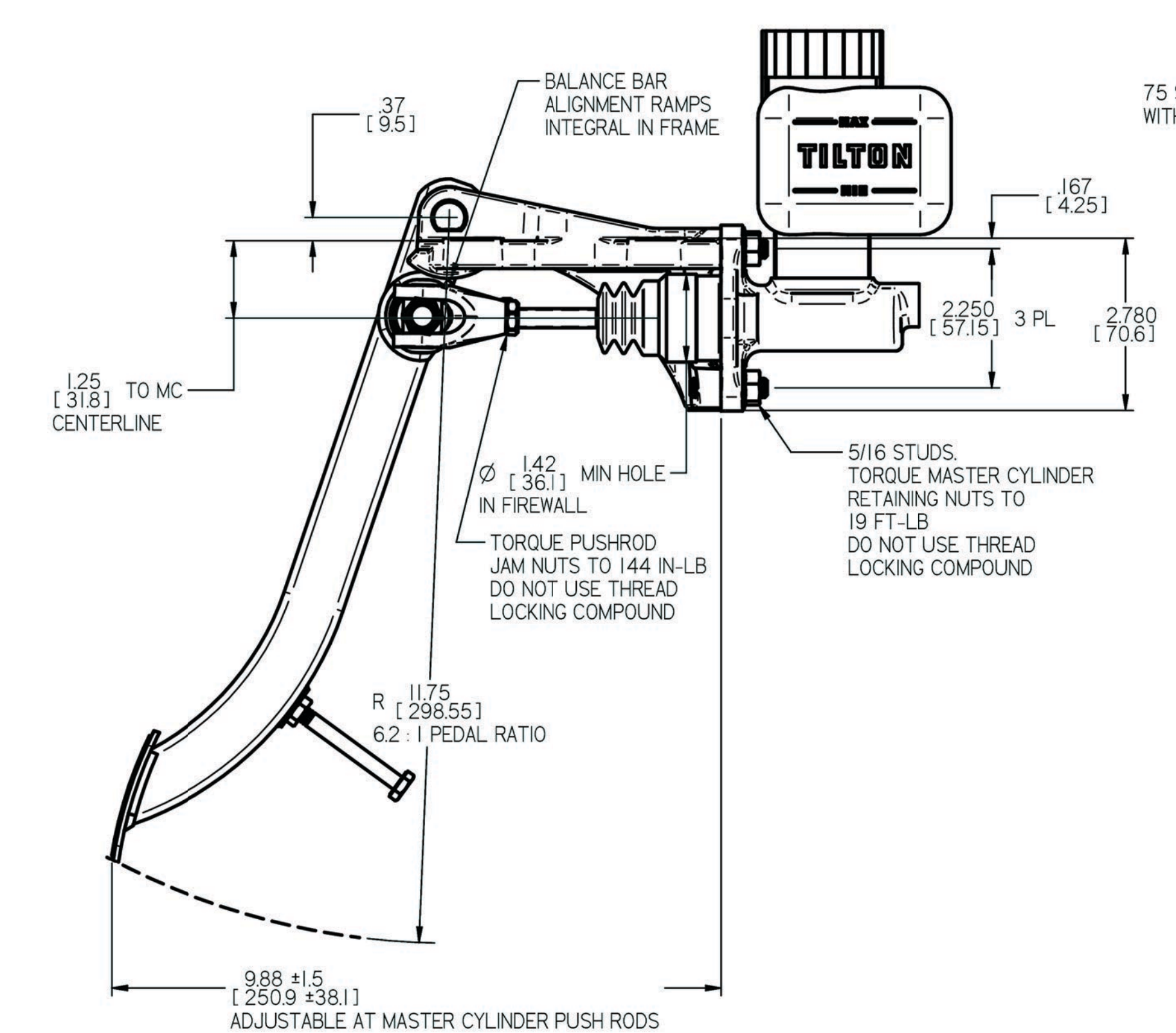
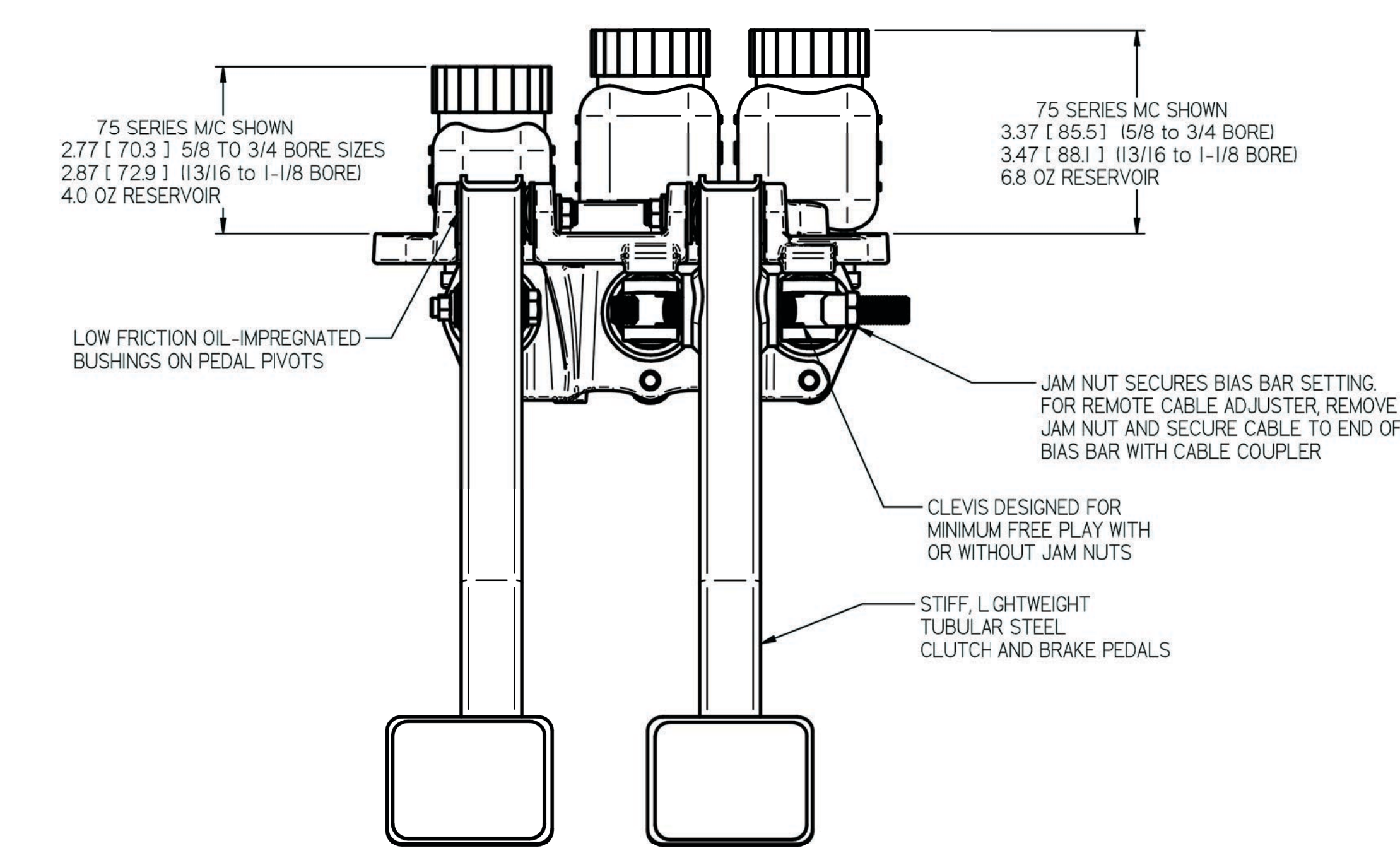
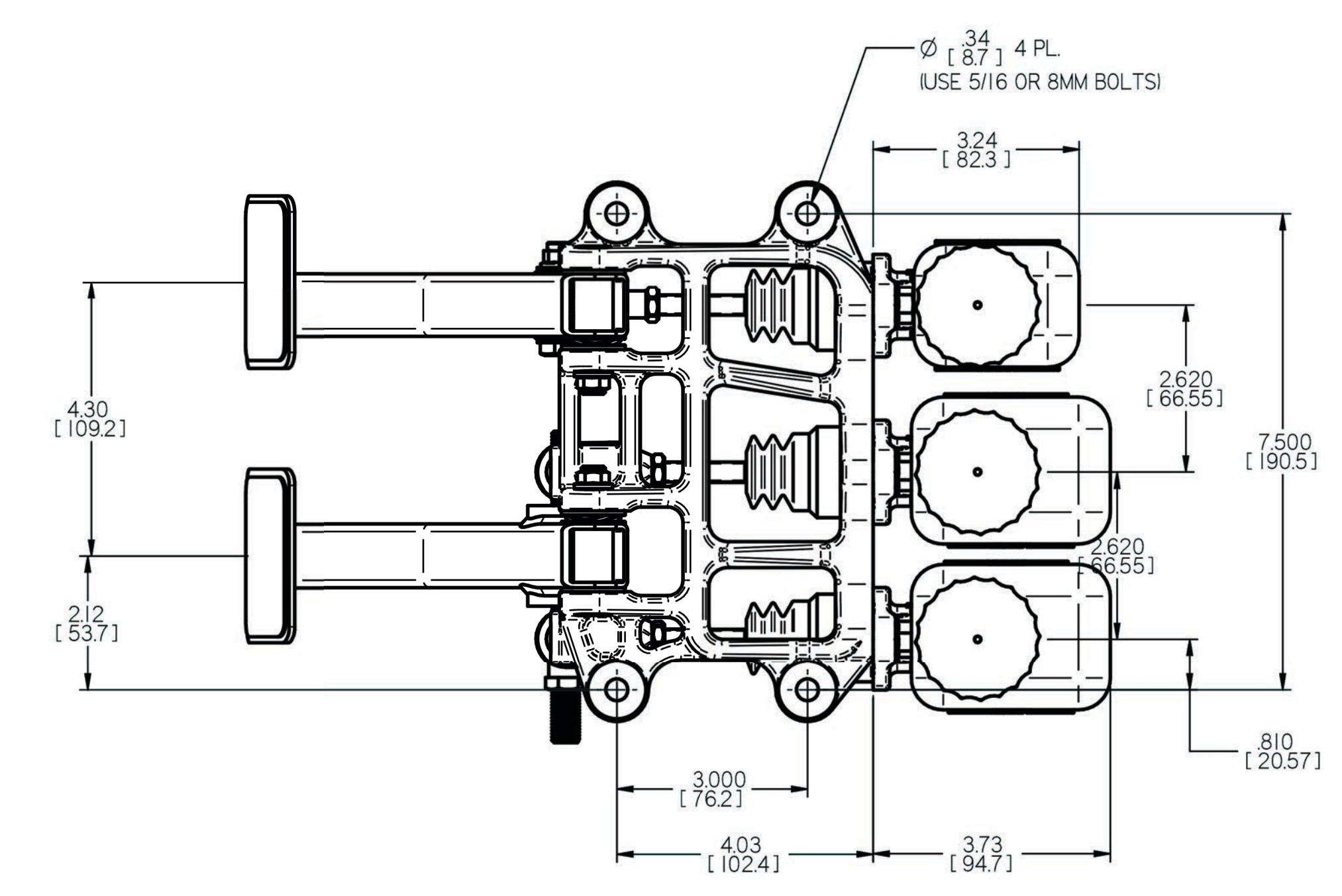
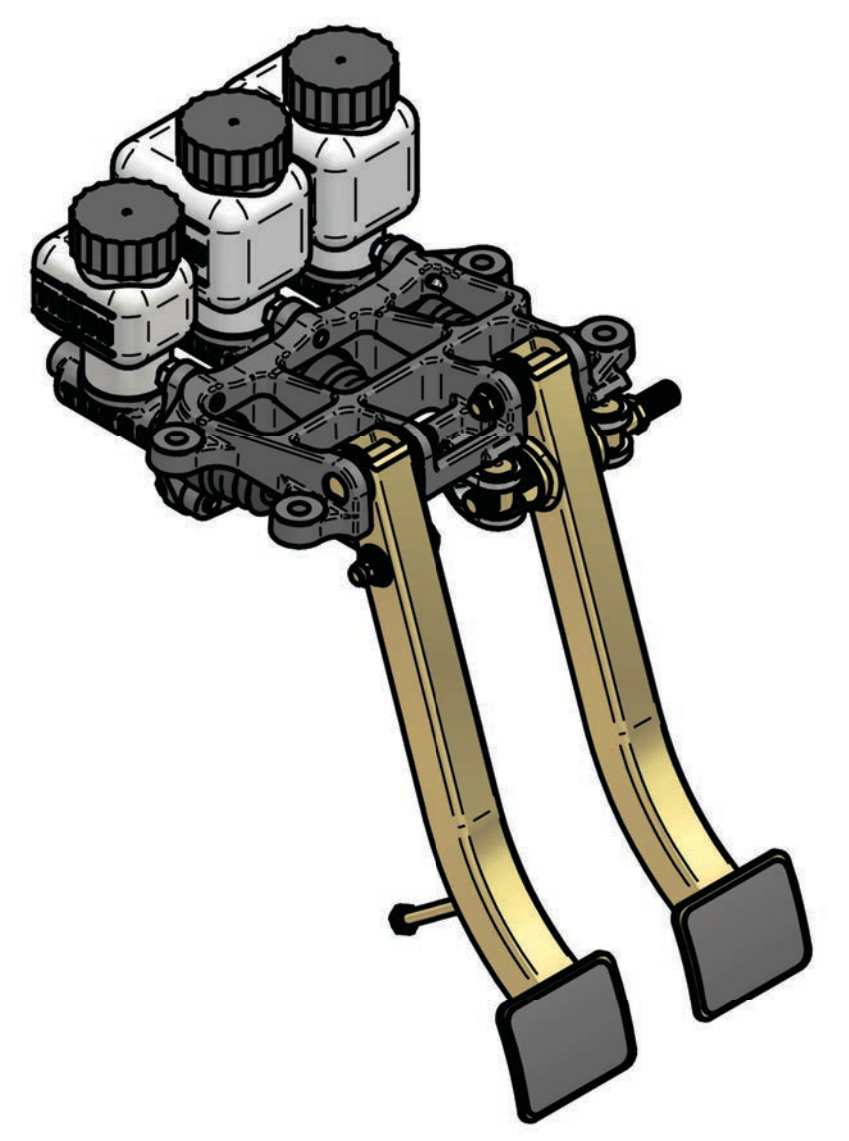
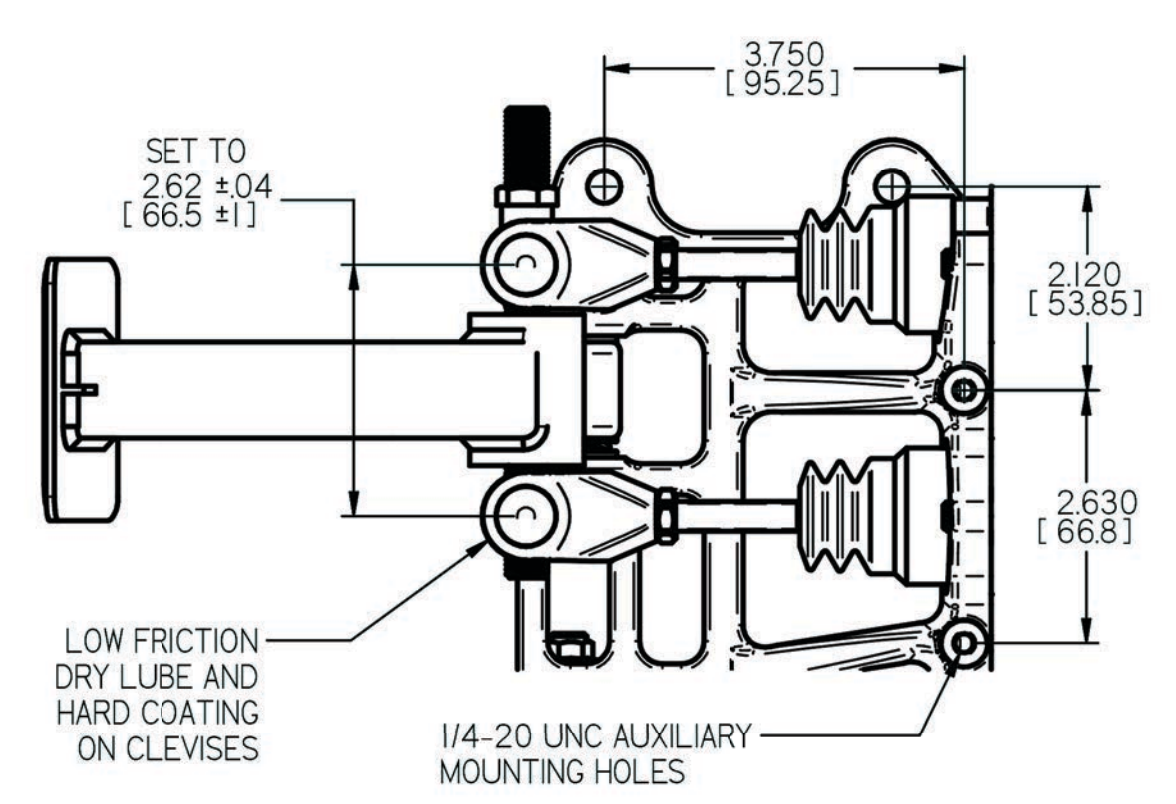

- NOTES:
- UNLESS OTHERWISE SPECIFIED, ALL DIMENSIONS ARE INCHES [MM].
  - DIMENSIONS ARE NOMINAL
  - WEIGHT : 4.55 LBS

TILTON ENGINEERING, INC. (805)688-2353 FAX (805)688-2745		25 EASY STREET P.O. BOX 1787 BUELLTON, CALIFORNIA 93427 USA	
TITLE: INSTALLATION DRAWING		600 SERIES FIREWALL STEEL PEDAL ASSEMBLY	
DRN BY VAN SCHMUS	CHK'D O'NEIL	SCALE 1:2	DWG 5123
P/N 72-601	DATE 07/20/06	SHEET 1 OF 1	

"This document contains proprietary information of TILTON ENGINEERING, INC., and its receipt or possession does not convey the rights to reproduce, disclose its contents, or to manufacture, use or sell anything it may describe. Reproduction, disclosure, or use without specific written authorization of TILTON ENGINEERING, INC. is strictly forbidden."

TILTON ENGINEERING INC.