

ZONE	CHKD	DATE	REV	ECN	CHANGE OR ADDITION
------	------	------	-----	-----	--------------------

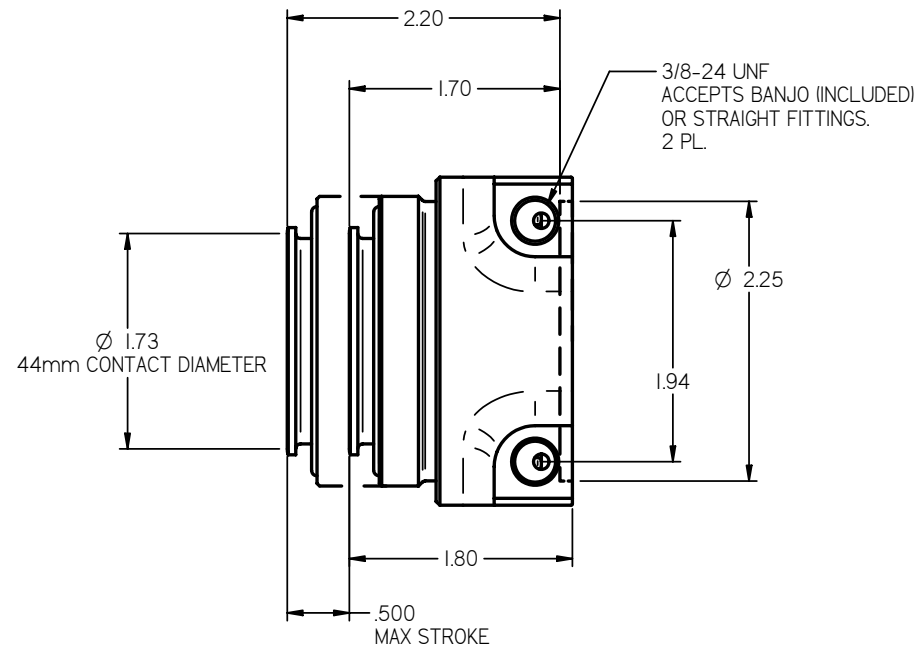
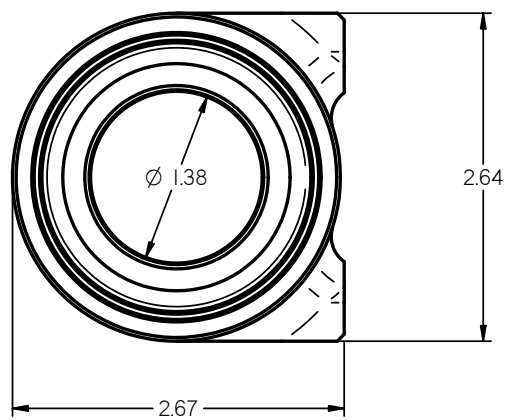
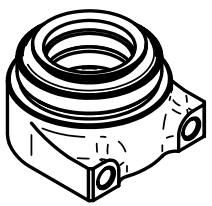

- NOTES:
1. DIMENSIONS IN INCHES EXCEPT WHERE NOTED.
 2. MUST SET POSITIVE STOP ON CLUTCH PEDAL PER INSTRUCTIONS.

TOLERANCES: UNLESS SPECIFIED OTHERWISE	
<u>DRILL HOLES</u>	
.X ± .020	.013-.040: +.001/- .001
.XX ± .010	.041-.130: +.002/- .001
.XXX ± .005	.131-.229: +.003/- .001
FRACT ± 1/32	.230-.500: +.004/- .001
ANGLE ± 1/2°	.501-.750: +.005/- .001
CONC (TIR) .005	.751-1.000: +.007/- .001

MAT'L SPEC COND HARD	
FINISH SPEC	

TILTON ENGINEERING, INC.		FAX 805/688-2745	
25 EASY STREET, P.O. BOX 1787, BUELLTON, CA 93427 805/688-2353			
TITLE:		INSTALLATION DRAWING, HRB HONDA B/K SERIES, ULTRA SHORT	
DRAWN BY	CHAMBERS	CHKD	SCALE 1 : 1
P/N	61-777	DATE	6/13/05
SHEET 1 OF 1			DWG 4972

This document contains proprietary information of TILTON ENGINEERING, INC., and its receipt or possession does not constitute an offer of any product, nor does it authorize manufacture, use or sale of anything it may describe. Reproduction, disclosure, or use without specific written authorization of TILTON ENGINEERING INC. is strictly forbidden.

