

ZONE	CHK'D	DATE	REV	ECN	CHANGE OR ADDITION
ALL	LUND	10/4/2013	A	1102	ADDED DUAL DIMENSIONS

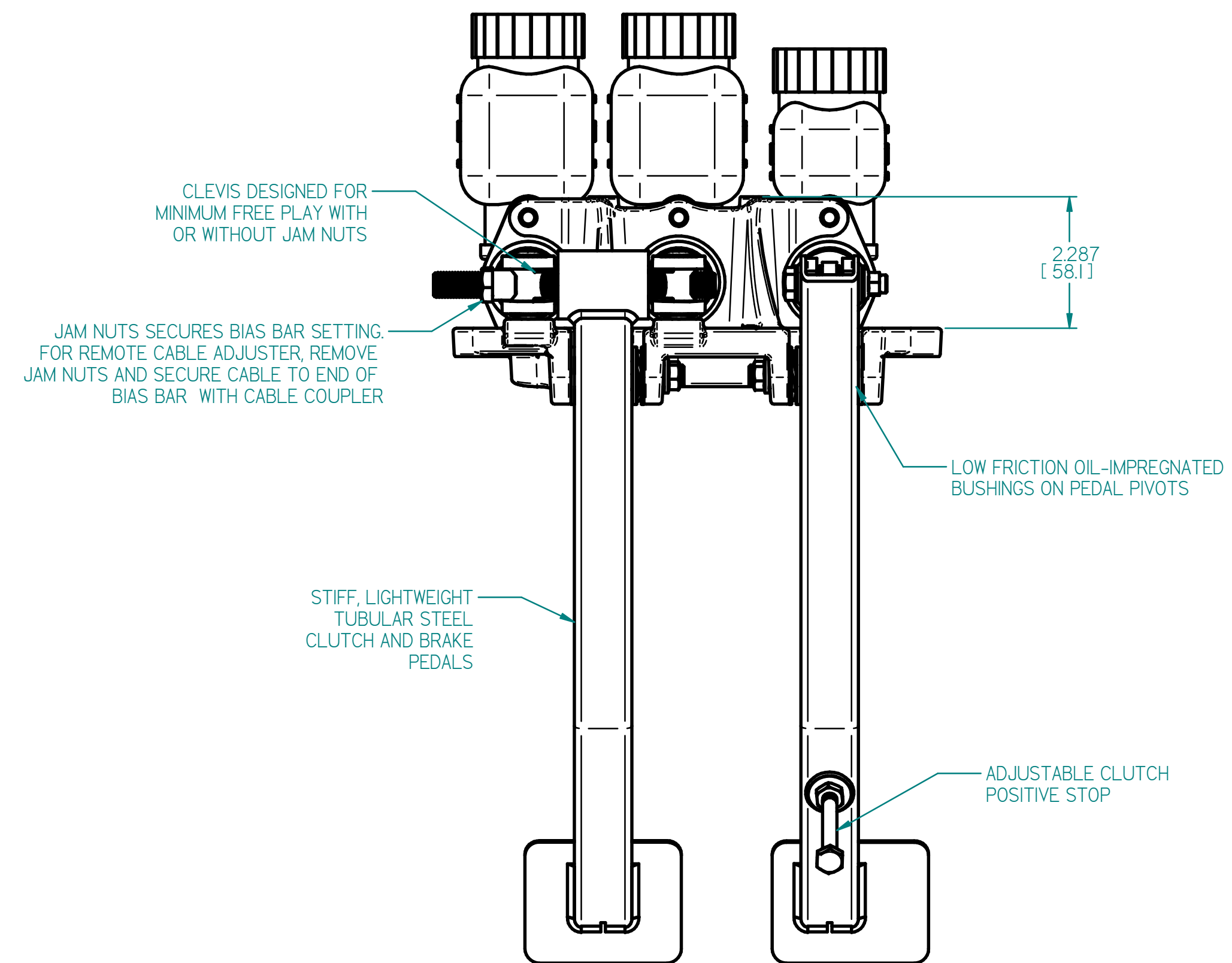
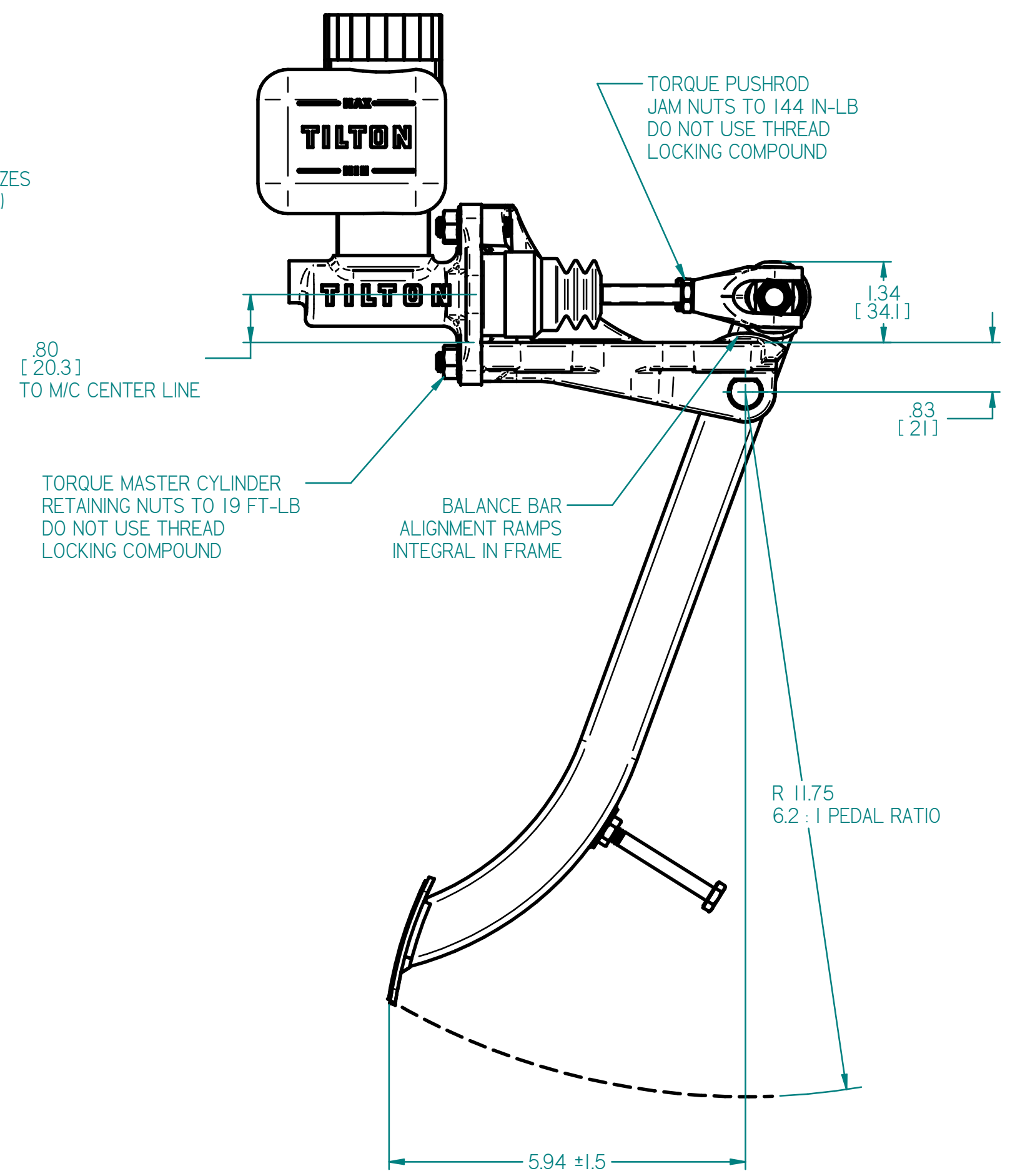
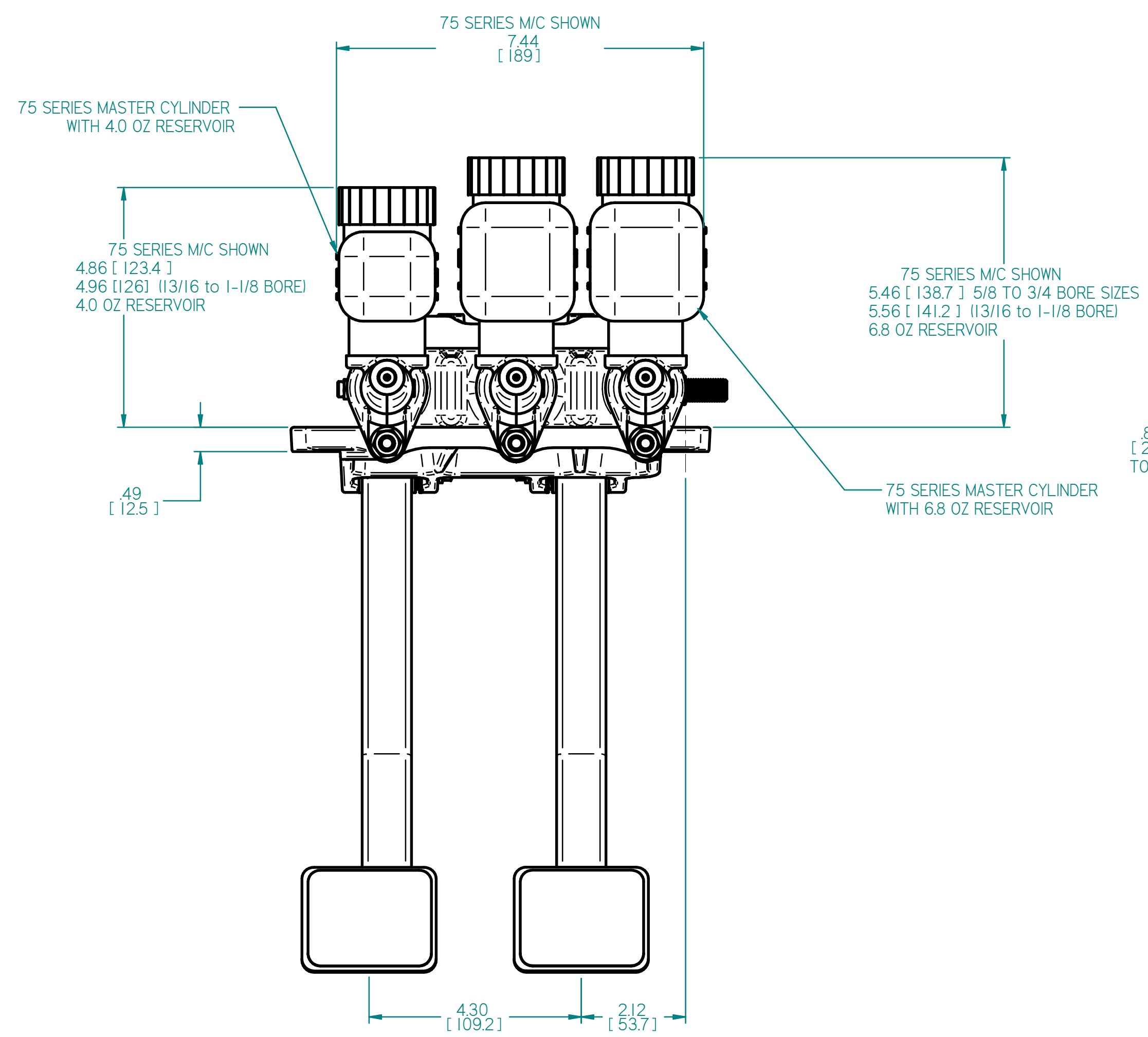
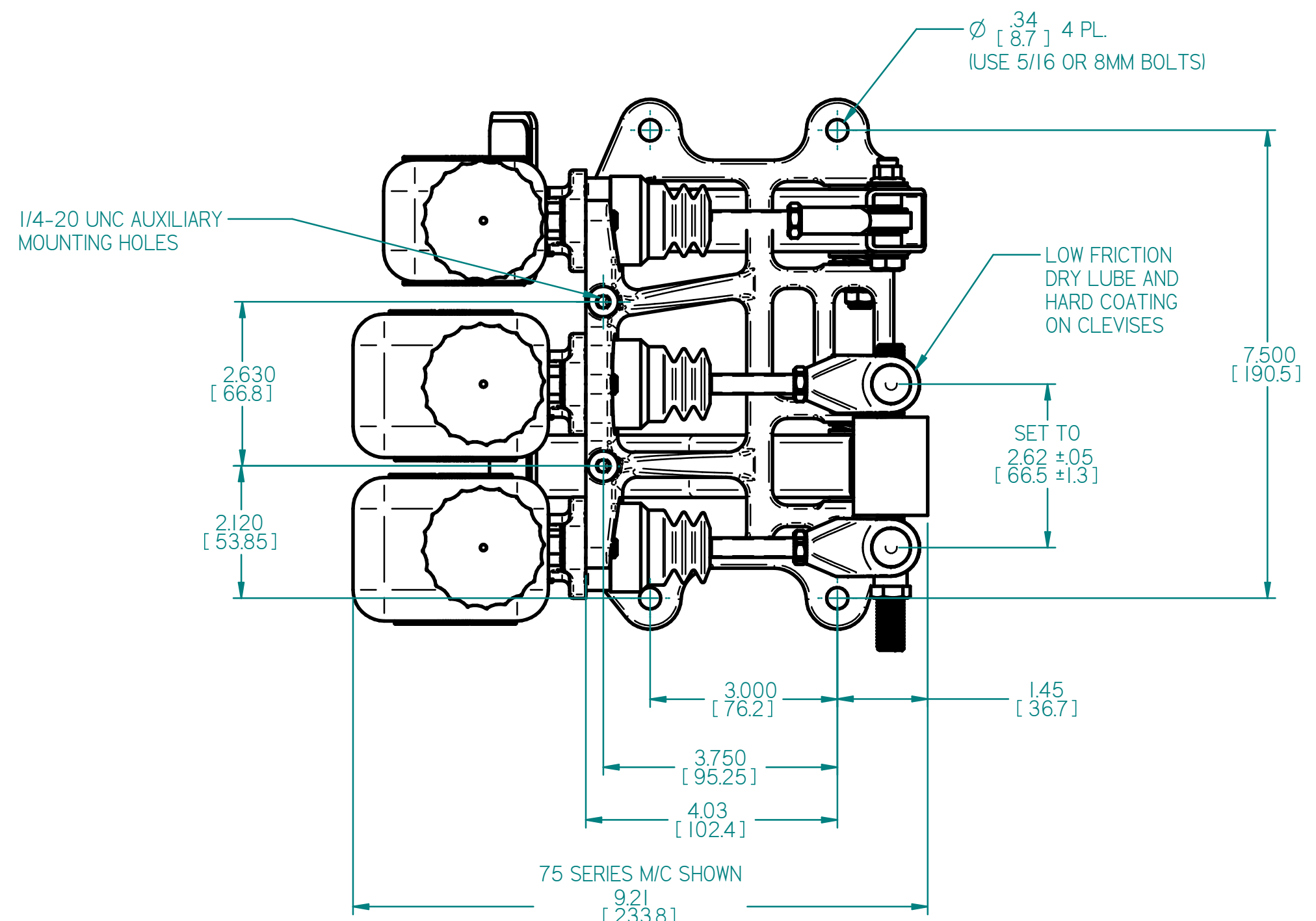
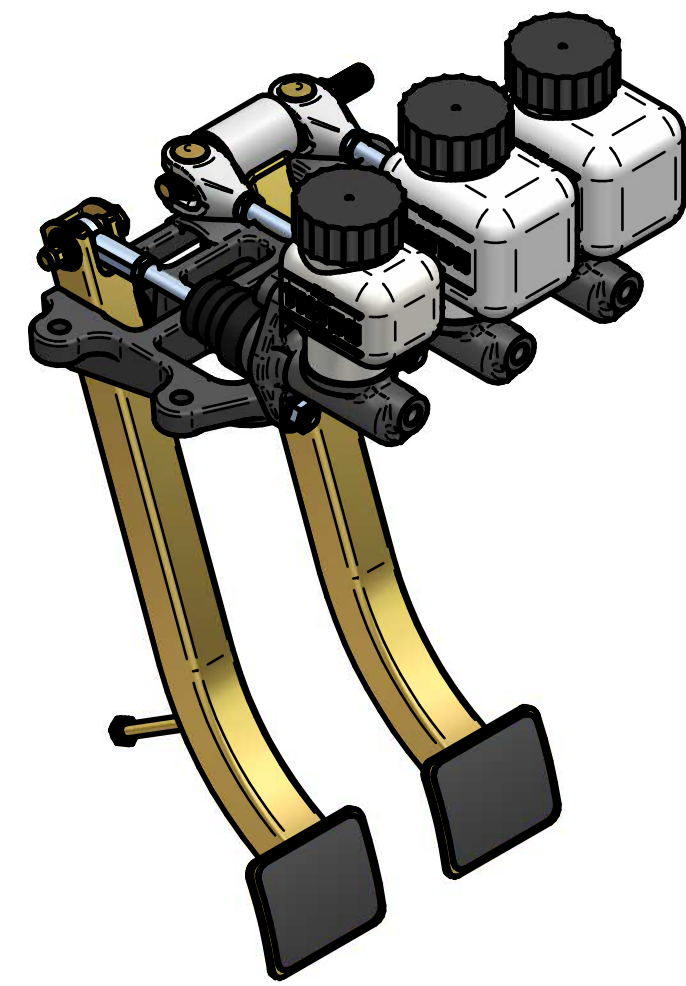

NOTES:
 1. UNLESS OTHERWISE SPECIFIED, ALL DIMENSIONS ARE INCHES, [MM].
 2. DIMENSIONS ARE NOMINAL
 3. WEIGHT : 5.1 LBS

PEDAL ASSEMBLY IS COMPATIBLE WITH TILTON ENGINEERING 73, 74, 75 AND 76 SERIES MASTER CYLINDERS, SOLD SEPARATELY
 75 SERIES MASTER CYLINDERS SHOWN HERE ARE FOR ILLUSTRATION PURPOSES ONLY AND ARE NOT INCLUDED WITH PEDAL ASSEMBLY

TILTON ENGINEERING, INC.		(805)688-2353 FAX (805)688-2745	
25 EASY STREET P.O. BOX 1787		BUELLTON, CALIFORNIA 93427 USA	
TITLE: INSTALLATION DRAWING			
600 SERIES OVERHUNG STEEL PEDAL ASSEMBLY			
DRN BY VAN SCHMUS	CHK'D O'NEIL	SCALE 1:2	DWG 5125
P/N 72-606	DATE 07/21/06	SHEET 1 OF 1	

TILTON ENGINEERING INC.

This document contains proprietary information of TILTON ENGINEERING, INC., and its receipt or possession does not convey the rights to reproduce, disclose its contents, or to manufacture, use or sell anything it may describe. Reproduction, disclosure, or use without specific written authorization of TILTON ENGINEERING, INC. is strictly forbidden.