

tilton®

1XXX Series

Typical Application

Fits many popular racing transmissions designed to accept 3-bolt pattern "Saab-type" hydraulic release bearings.



Hydraulic Release Bearings | GEN3

Tilton HRBs

Tilton offers a wide range of hydraulic release bearings (HRB) for use with push-type clutches. Hydraulic release bearings are available for use with smaller diameter racing clutches (4.5", 5.5", & 7.25") and most OE-type clutches.

Tilton hydraulic release bearings are designed to eliminate the need for mechanical linkages, pivot balls, spacers and external slave cylinders.

Advanced manufacturing | Renowned Tilton quality

1000-Series HRB 52mm Bearing

[Installation Drawing](#)

12XX-Series HRB 44mm Bearing

[Installation Drawing](#)

1100-Series HRB Flat-face Bearing

[Installation Drawing](#)

13XX-Series HRB 38mm Bearing

[Installation Drawing](#)



Monoseal Technology



Constant Contact Design



Proprietary Coatings



High Quality Bearings

Tilton's unique monoseal technology is incorporated into all hydraulic release bearings. The high temperature monoseal features a quad tensioner to ensure proper seal tension. Seals have been tested to hundreds of thousands of actuations without failure. Tilton hydraulic release bearings feature a wiper seal to provide protection from debris entering the bore.

The constant contact design of Tilton hydraulic release bearings maintains pedal feel even as the clutch wears. In addition, Tilton hydraulic release bearings self-adjust for clutch wear.

Tilton hydraulic release bearings feature superior materials and proprietary low friction coatings, providing longevity and consistency.

Tilton hydraulic release bearing assemblies feature high-quality bearings to provide smooth and reliable operation.

1000-Series HRB

Flush-mount | **52mm** bearing



Mount:	3-bolt "Saab-type" pattern
Bearing contact diameter:	2.05" (52mm)
Piston Area:	1.215 in ² (784mm ²)
Max Stroke:	.700" (17.8 mm)
Ports:	AN3 (3/8"-24)
Weight:	.85 lbs
Includes:	AN3 fittings (2)

Part Number	Overall Height
60-1000	2.04" (51.8mm)

5.5" - 8.5" clutches

Radius face bearing

Billet Aluminum

Installation Drawing

60-1000 HRB

ITEM	PART NUMBER	DESCRIPTION	QTY
1	62-1000	BODY	1
2	62-617	WIPER	1
3	62-612	PISTON	1
4	62-614	HYDRAULIC SEAL	1
5	62-002	BEARING	1
6	73-820	FITTING	2

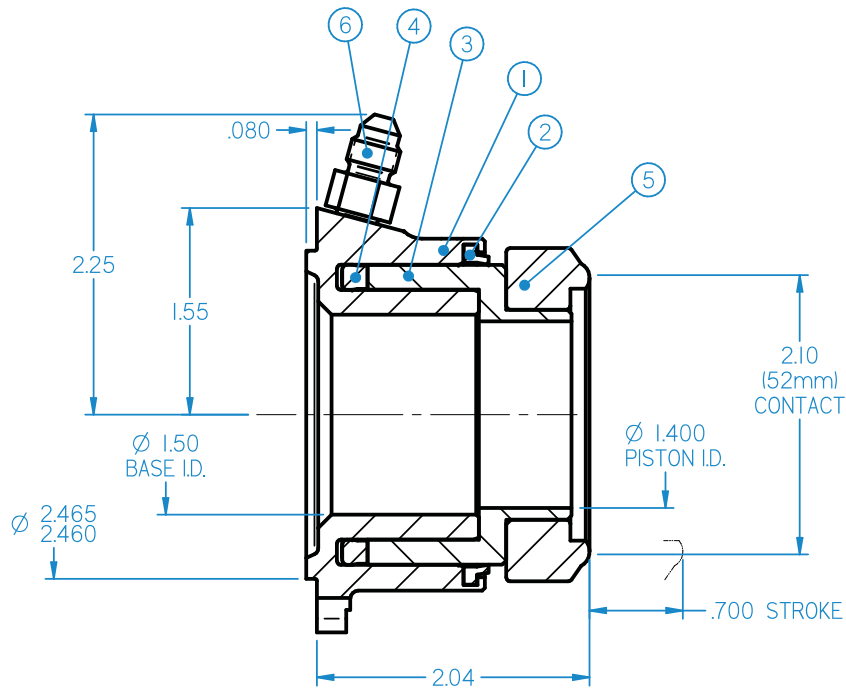

SECTION A-A

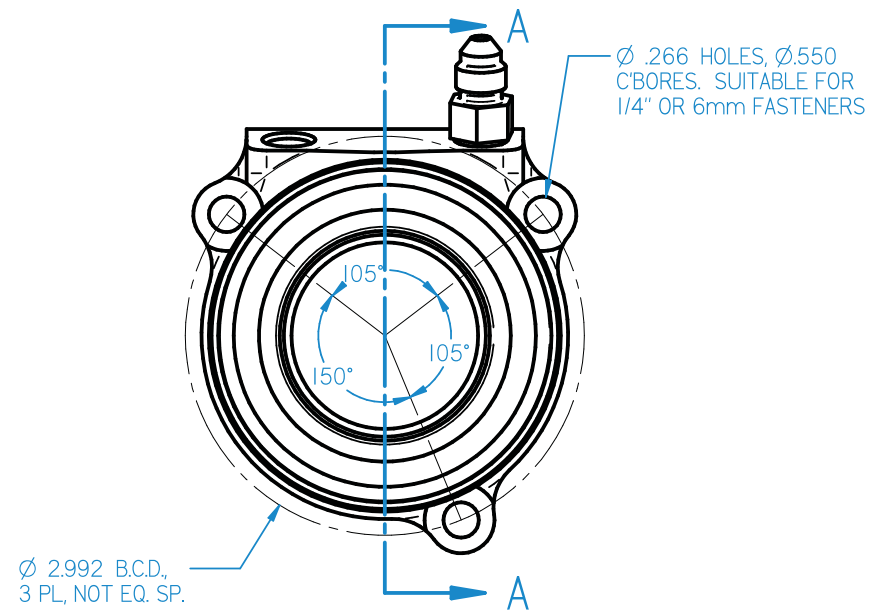

INSTALLATION NOTES

1. USE ONLY WITH DOT-3 OR DOT-4 BRAKE FLUID.
2. NO INTERNAL TRAVEL LIMITER. MUST BE USED WITH CLUTCH PEDAL STOP.
3. SEAL REBUILD KIT = 62-905.
4. SEAL INSTALLATION TOOL = 96-002.
5. HYDRAULIC AREA = 1.215 SQ IN.
6. EITHER PORT MAY BE USED FOR FEED OR BLEED.
7. ORIENTATE BLEED PORT WITH 10 DEGREES OF TOP CENTER TO FACILITATE BLEEDING PROCESS.
8. BOTH PORTS 3/8-24 UNF X .28 THREAD DEPTH.

1100-Series HRB

Flush-mount | **Flat face** bearing



Mount:	3-bolt "Saab-type" pattern
Bearing contact diameter:	1.71" – 3.03" (43.4mm – 77.0mm)
Piston Area:	1.215 in ² (784mm ²)
Max Stroke:	.700" (17.8 mm)
Ports:	AN3 (3/8"-24)
Weight:	.95 lbs
Includes:	AN3 fittings (2)

Part Number	Overall Height
60-1100	1.79" (45.5mm)

8.5" - 11.0" bent finger clutches

Flat face bearing

Billet Aluminum

Installation Drawing

60-1100 HRB

ITEM	PART NUMBER	DESCRIPTION	QTY
1	62-1000	BODY	1
2	62-617	WIPER	1
3	62-612	PISTON	1
4	62-614	HYDRAULIC SEAL	1
5	62-618	BEARING	1
6	73-820	FITTING	2

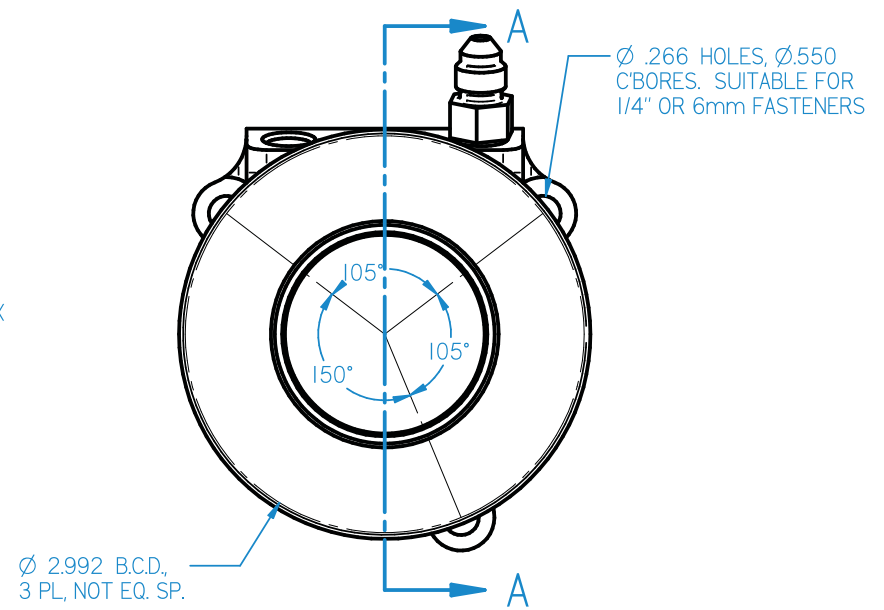
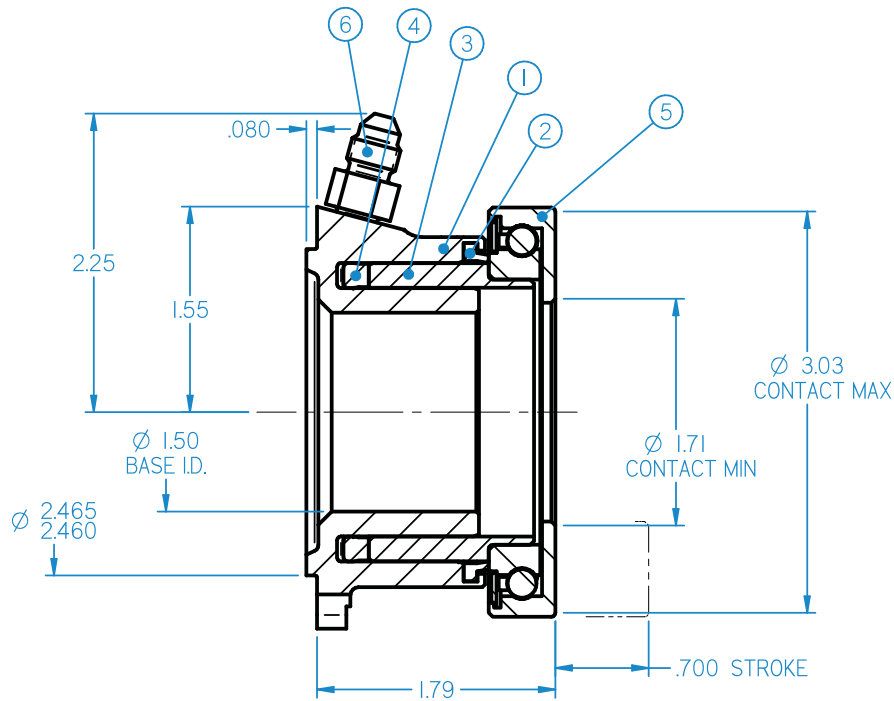

INSTALLATION NOTES

1. USE ONLY WITH DOT-3 OR DOT-4 BRAKE FLUID.
2. NO INTERNAL TRAVEL LIMITER. MUST BE USED WITH CLUTCH PEDAL STOP.
3. SEAL REBUILD KIT = 62-905.
4. SEAL INSTALLATION TOOL = 96-002.
5. HYDRAULIC AREA = 1.215 SQ IN.
6. EITHER PORT MAY BE USED FOR FEED OR BLEED.
7. ORIENTATE BLEED PORT WITH 10 DEGREES OF TOP CENTER TO FACILITATE BLEEDING PROCESS.
8. BOTH PORTS 3/8-24 UNF X .28 THREAD DEPTH.

12XX-Series HRB

Flush-mount | **44mm** bearing



5.5" - 7.25" clutches

Radius face bearing

Billet Aluminum

Mount:	3-bolt "Saab-type" pattern
Bearing contact diameter:	1.75" (44mm)
Piston Area:	1.215 in² (784mm²)
Max Stroke:	.700" (17.8 mm)
Ports:	AN3 (3/8"-24)
Weight:	.70 lbs (varies by p/n)
Includes:	AN3 fittings (2)

Part Number	Overall Height	
	with shim	without shim
60-1200	1.87" (47.5mm)	1.82" (46.2mm)
60-1210	1.97" (50.0mm)	1.92" (48.8mm)
60-1220	2.07" (52.3mm)	2.02" (51.3mm)
60-1230	2.17" (55.1mm)	2.12" (53.8mm)
60-1240	2.27" (57.7mm)	2.22" (56.4mm)
60-1250	2.37" (60.2mm)	2.32" (58.9mm)
60-1260	2.47" (62.7mm)	2.42" (61.5mm)
60-1270	2.57" (65.3mm)	2.52" (64.0mm)
60-1280	2.67" (67.8mm)	2.62" (66.5mm)
60-1290	2.77" (70.4mm)	2.72" (69.0mm)

HRB comes from Tilton factory with shim installed in piston under the bearing. Shim can be removed by customer to gain .050" (1.3mm) additional clearance.

Installation Drawing

60-12XX HRB

ITEM	PART NUMBER	DESCRIPTION	QTY
1	62-1000	HYDRAULIC BASE	1
2	62-617	WIPER	1
3	SEE CHART	PISTON	1
4	62-614	HYDRAULIC SEAL	1
5	62-031	BEARING	1
6	73-820	FITTING, AN-3	2
7	62-903	SHIM	1

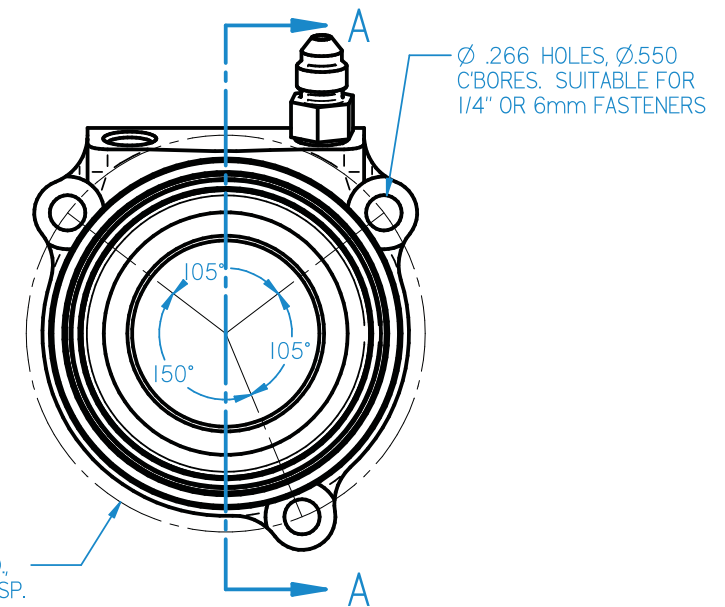
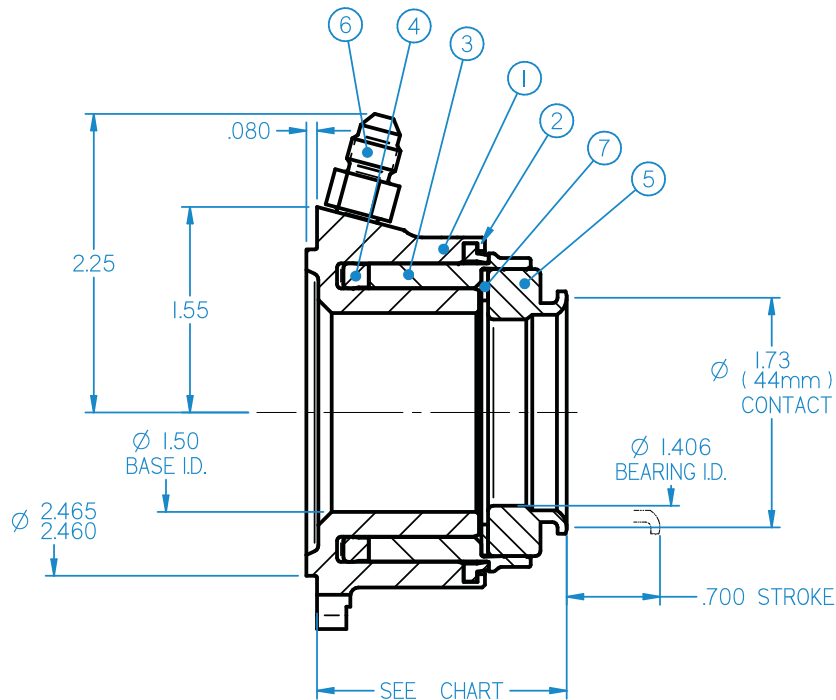

CHART OF AVAILABLE ASSEMBLIES		
HEIGHT	ASSY PN	PISTON PN
1.82"-1.87"	60-1200	62-6000
1.92"-1.97"	60-1210	62-6001
2.02"-2.07"	60-1220	62-6002
2.12"-2.17"	60-1230	62-6003
2.22"-2.27"	60-1240	62-6004
2.32"-2.37"	60-1250	62-6005
2.42"-2.47"	60-1260	62-6006
2.52"-2.57"	60-1270	62-6007
2.62"-2.67"	60-1280	62-6008
2.72"-2.77"	60-1290	62-6009

INSTALLATION NOTES

1. USE ONLY WITH DOT-3 OR DOT-4 BRAKE FLUID.
2. NO INTERNAL TRAVEL LIMITER. MUST BE USED WITH CLUTCH PEDAL STOP.
3. SEAL REBUILD KIT = 62-905.
4. SEAL INSTALLATION TOOL = 96-002.
5. HYDRAULIC AREA = 1.215 SQ IN.
6. EITHER PORT MAY BE USED FOR FEED OR BLEED.
7. ORIENTATE BLEED PORT WITH 10 DEGREES OF TOP CENTER TO FACILITATE BLEEDING PROCESS.
8. UNIT IS SHIPPED WITH SHIM 62-903 (.050" THICK) INSTALLED UNDER THE BEARING WHICH MAY BE REMOVED FOR ADDITIONAL CLEARANCE.
9. BOTH PORTS 3/8-24 UNF X .28 THREAD DEPTH.

13XX-Series HRB

Flush-mount | **38mm** bearing



4.5" - 5.5" clutches

Radius face bearing

Billet Aluminum

Mount: **3-bolt "Saab-type" pattern**
Bearing contact diameter: **1.50" (38mm)**
Piston Area: **1.215 in² (784mm²)**
Max Stroke: **.700" (17.8 mm)**
Ports: **AN3 (3/8"-24)**
Weight: **.75 lbs (varies by p/n)**
Includes: **AN3 fittings (2)**

Part Number	Overall Height	
	<i>with shim</i>	<i>without shim</i>
60-1300	1.87" (47.5mm)	1.82" (46.2mm)
60-1310	1.97" (50.0mm)	1.92" (48.8mm)
60-1320	2.07" (52.3mm)	2.02" (51.3mm)
60-1330	2.17" (55.1mm)	2.12" (53.8mm)
60-1340	2.27" (57.7mm)	2.22" (56.4mm)
60-1350	2.37" (60.2mm)	2.32" (58.9mm)
60-1360	2.47" (62.7mm)	2.42" (61.5mm)
60-1370	2.57" (65.3mm)	2.52" (64.0mm)
60-1380	2.67" (67.8mm)	2.62" (66.5mm)
60-1390	2.77" (70.4mm)	2.72" (69.0mm)

HRB comes from Tilton factory with shim installed in piston under the bearing. Shim can be removed by customer to gain .050" (1.3mm) additional clearance.

Installation Drawing

60-13XX HRB

ITEM	PART NUMBER	DESCRIPTION	QTY
1	62-1000	HYDRAULIC BASE	1
2	62-617	WIPER	1
3	SEE CHART	PISTON	1
4	62-614	HYDRAULIC SEAL	1
5	62-031	BEARING	1
6	73-820	FITTING, AN-3	2
7	62-903	SHIM	1

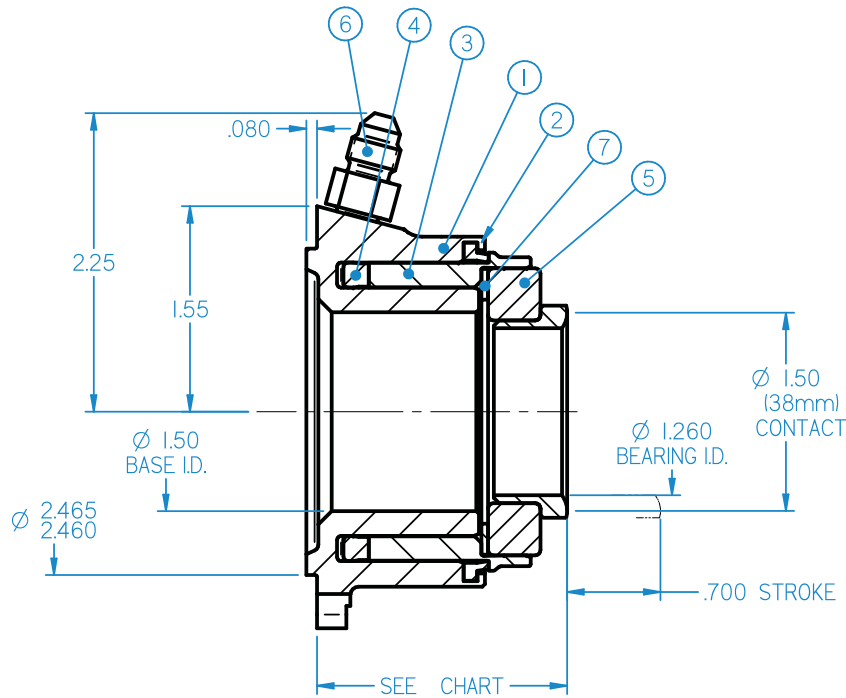

SECTION A-A

CHART OF AVAILABLE ASSEMBLIES		
HEIGHT	ASSY PN	PISTON PN
1.82"-1.87"	60-1300	62-6000
1.92"-1.97"	60-1310	62-6001
2.02"-2.07"	60-1320	62-6002
2.12"-2.17"	60-1330	62-6003
2.22"-2.27"	60-1340	62-6004
2.32"-2.37"	60-1350	62-6005
2.42"-2.47"	60-1360	62-6006
2.52"-2.57"	60-1370	62-6007
2.62"-2.67"	60-1380	62-6008
2.72"-2.77"	60-1390	62-6009

*HEIGHTS SHOWN IN CHART ARE WITH AND WITHOUT 62-903 SHIM

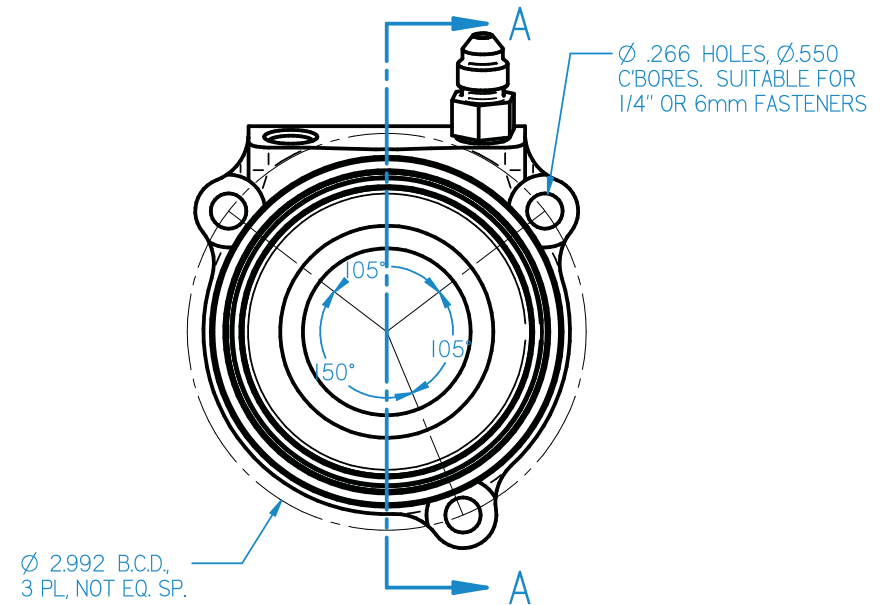

INSTALLATION NOTES

1. USE ONLY WITH DOT-3 OR DOT-4 BRAKE FLUID.
2. NO INTERNAL TRAVEL LIMITER. MUST BE USED WITH CLUTCH PEDAL STOP.
3. SEAL REBUILD KIT = 62-905.
4. SEAL INSTALLATION TOOL = 96-002.
5. HYDRAULIC AREA = 1.215 SQ IN.
6. EITHER PORT MAY BE USED FOR FEED OR BLEED.
7. ORIENTATE BLEED PORT WITH 10 DEGREES OF TOP CENTER TO FACILITATE BLEEDING PROCESS.
8. UNIT IS SHIPPED WITH SHIM 62-903 (.050" THICK) INSTALLED UNDER THE BEARING WHICH MAY BE REMOVED FOR ADDITIONAL CLEARANCE.
9. BOTH PORTS 3/8-24 UNF X .28 THREAD DEPTH.



www.tiltonracing.com

