

8	7	6	5	4	3	2	1
REV	ECN	DATE	BY	CHANGE OR ADDITION			

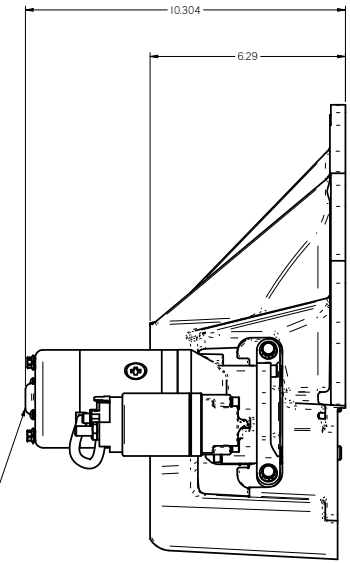
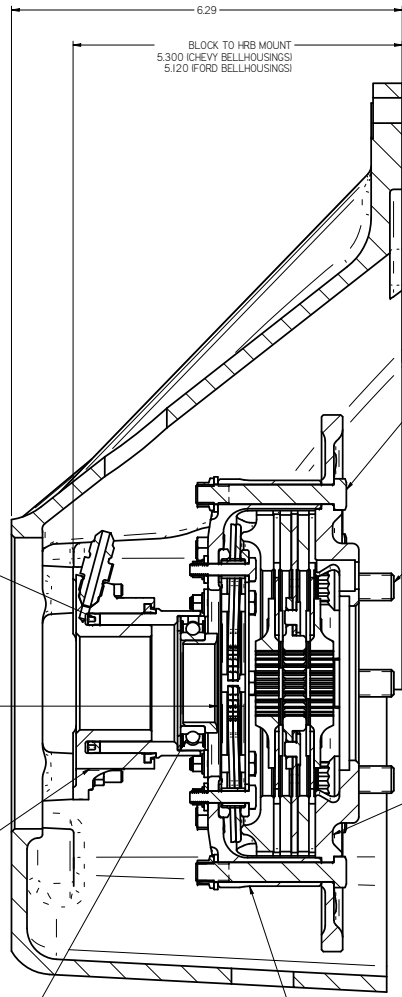
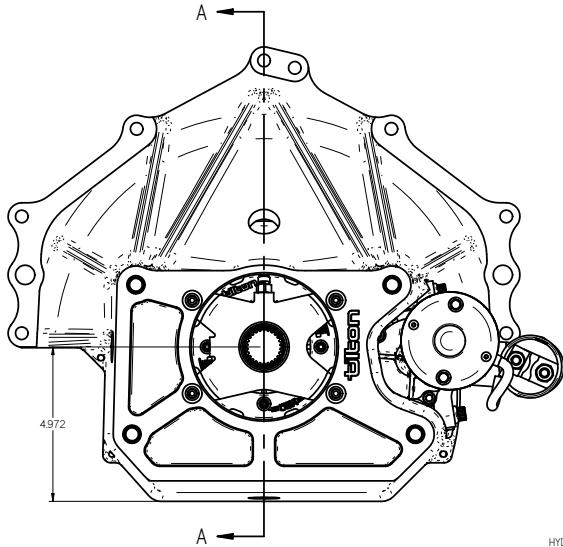
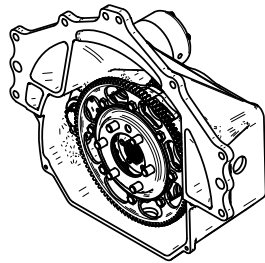
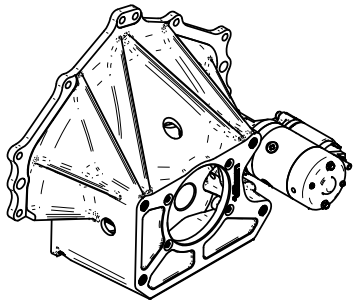

- BLOCK TO HRB MOUNT
5.300 (CHEVY BELLHOUSINGS)
5.120 (FORD BELLHOUSINGS)
- BELLHOUSING
P/N 52-681 (CHEVY)
P/N 52-682 (FORD)
- BOLT KIT
P/N 95-003-5 (3 DISC METALLIC CLUTCHES)
P/N 95-004-5 (4 DISC METALLIC CLUTCHES)
P/N 95-061 (3 DISC CARBON CLUTCHES)
- CRANK BOLT KIT
P/N 95-952-6 (ALL EXCEPT CHEVY LS OR CHEVY R07)
P/N 95-940-6 (CHEVY LS ENGINE ONLY)
P/N 95-952-8 (CHEVY R07 ENGINE ONLY)
- SEAL REPAIR KIT
P/N 62-905
- .J8 ±.06 RECOMMENDED RANGE
(NEW CLUTCH, HRB COMPRESSED)
- STARTER (1/3T PINION)
P/N 54-41073
- 102T FLYWHEEL
P/N 51-56 (EARLY CHEVY)
P/N 51-604 (CHEVY CRATE EX BAL)
P/N 51-659 (CHEVY LS)
P/N 51-665 (CHEVY R07)
P/N 51-653 (FORD)
- CLUTCH
P/N 67-003HG (THREE DISC METALLIC CLUTCH)
CLUTCH DISC PACK (3 DISC)
P/N 64140-9-ASA-36 (I-5/32 X 26T SPLINE HUBS)
CLUTCH
P/N 67-004HG (FOUR DISC METALLIC CLUTCH)
CLUTCH DISC PACK (4 DISC)
P/N 64140-9-ACC-36 (I-5/32 X 26T SPLINE HUBS)
CLUTCH
P/N 6553HSG-S (THREE DISC CARBON CLUTCH)
DRIVE HUB - 3 DISC CARBON CLUTCH
P/N 655-351S-36 (I-5/32 X 26T SPLINE)
- HYDRAULIC RELEASE BEARING
P/N 60-5340 (3 DISC METALLIC CLUTCH APPLICATIONS)
P/N 60-5310 (4 DISC METALLIC CLUTCH APPLICATIONS)
P/N 60-5330 (3 DISC CARBON CLUTCH APPLICATIONS)
- REPLACEMENT BEARING
P/N 62-006

SECTION A-A

POPULAR BELLHOUSING KIT PART NUMBERS	
PART NUMBER	DESCRIPTION
52-31130	BH KIT, 102T ALUM, CHEVY (EARLY), 5.5" METALLIC, 3 DISC
52-31140	BH KIT, 102T ALUM, CHEVY (EARLY), 5.5" METALLIC, 4 DISC
52-31230	BH KIT, 102T ALUM, CHEVY (EARLY), 5.5" CARBON, 3 DISC
52-32130	BH KIT, 102T ALUM, FORD, 5.5" METALLIC, 3 DISC
52-32140	BH KIT, 102T ALUM, FORD, 5.5" METALLIC, 4 DISC
52-32230	BH KIT, 102T ALUM, FORD, 5.5" CARBON, 3 DISC
52-33130	BH KIT, 102T ALUM, CHEVY (LS), 5.5" METALLIC, 3 DISC
52-33140	BH KIT, 102T ALUM, CHEVY (LS), 5.5" METALLIC, 4 DISC
52-33230	BH KIT, 102T ALUM, CHEVY (LS), 5.5" CARBON, 3 DISC
52-34130	BH KIT, 102T ALUM, CHEVY (EX BAL CRATE), 5.5" METALLIC, 3 DISC
52-35130	BH KIT, 102T ALUM, CHEVY (R07), 5.5" METALLIC, 3 DISC
52-35230	BH KIT, 102T ALUM, CHEVY (R07), 5.5" CARBON, 3 DISC

- NOTES:
- DIMENSIONS AND TOLERANCES PER ASME Y14.5 - 2009
 - UNLESS OTHERWISE SPECIFIED, ALL DIMENSIONS ARE IN INCHES.
 - UNLESS OTHERWISE SPECIFIED, ALL KITS COME WITH 1-5/32 X 26T SPLINE HUBS. ADD SUFFIX "-58" TO END OF KIT PART NUMBER TO SPECIFY 1-1/4 X 29T SPLINE HUBS.

TILTON ENGINEERING, INC.
 25 EASY STREET P.O. BOX 1787 BUELLTON, CALIFORNIA 93427 USA
 PHONE: (805) 688-2353 FAX: (805) 688-2745 WWW.TILTONRACING.COM



TITLE: BELLHOUSING KIT
 REAR STARTER, 102T FLYWHEEL, 5.5" CLUTCHES

DRN BY WAHL	CHKD	SCALE 1:1	DWG 7638	REV NC
P/N AS NOTED	DATE 2/25/2022	SHEET 1 OF 1		

This document contains proprietary information of TILTON ENGINEERING, INC., and its receipt or possession does not convey the rights to reproduce, disclose its contents, or to manufacture, use or sell anything it may describe. Reproduction, disclosure, or use without specific written authorization of TILTON ENGINEERING, INC. is strictly forbidden.

TILTON ENGINEERING