

4

3

2

1

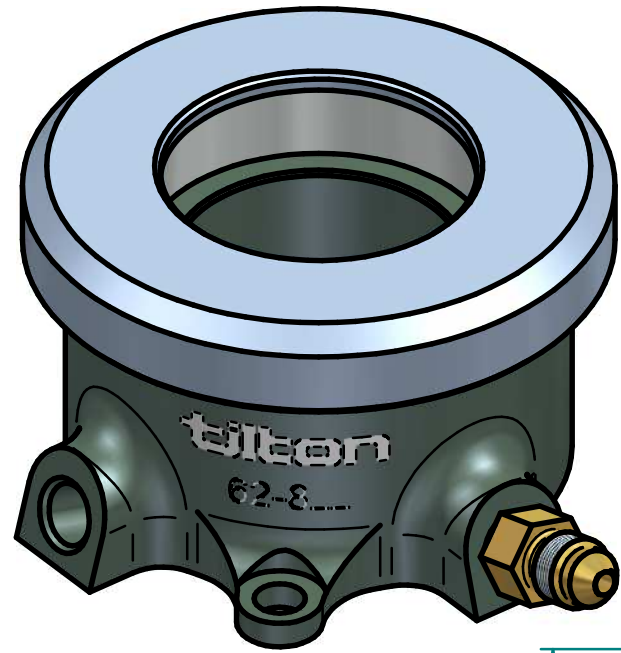

ITEM	PART NUMBER	DESCRIPTION	QTY
1	62-617	WIPER	1
2	62-614	HYDRAULIC SEAL	1
3	73-820	FITTING, AN-3	2
4	62-806	HYDRAULIC BASE	1
5	62-618	BEARING	1
6	62-6100	PISTON	1

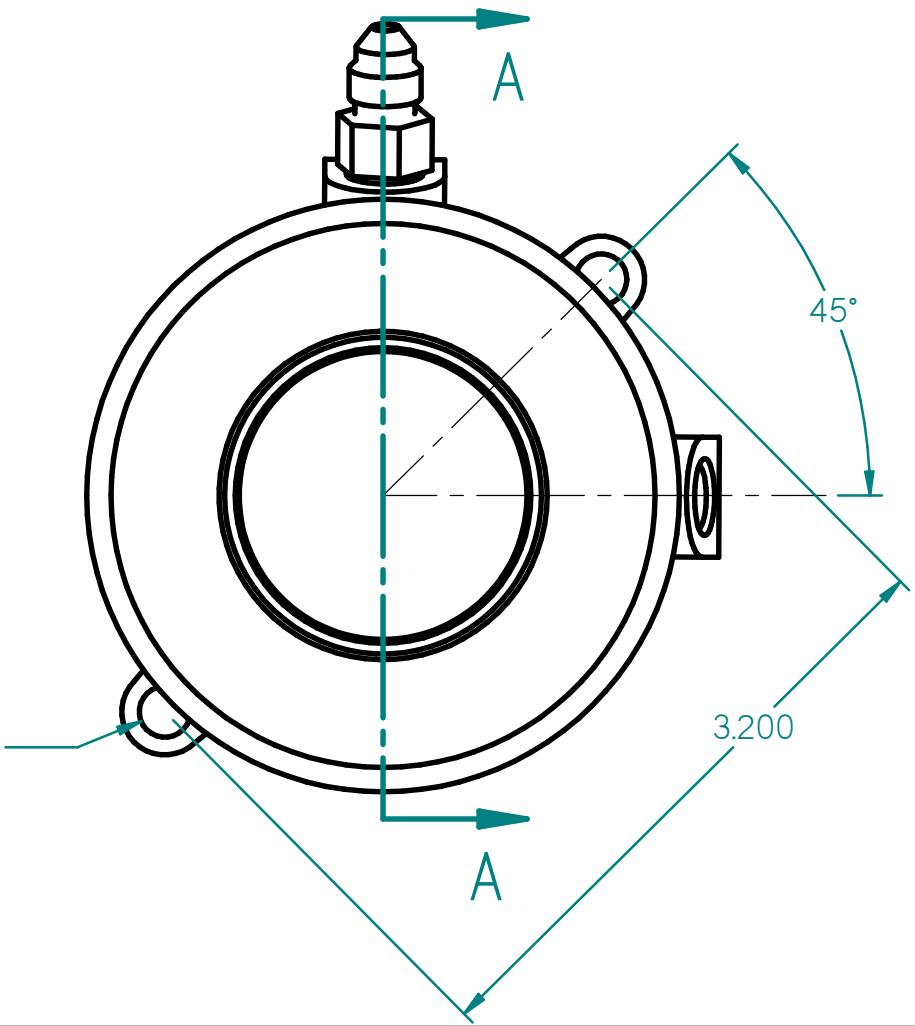
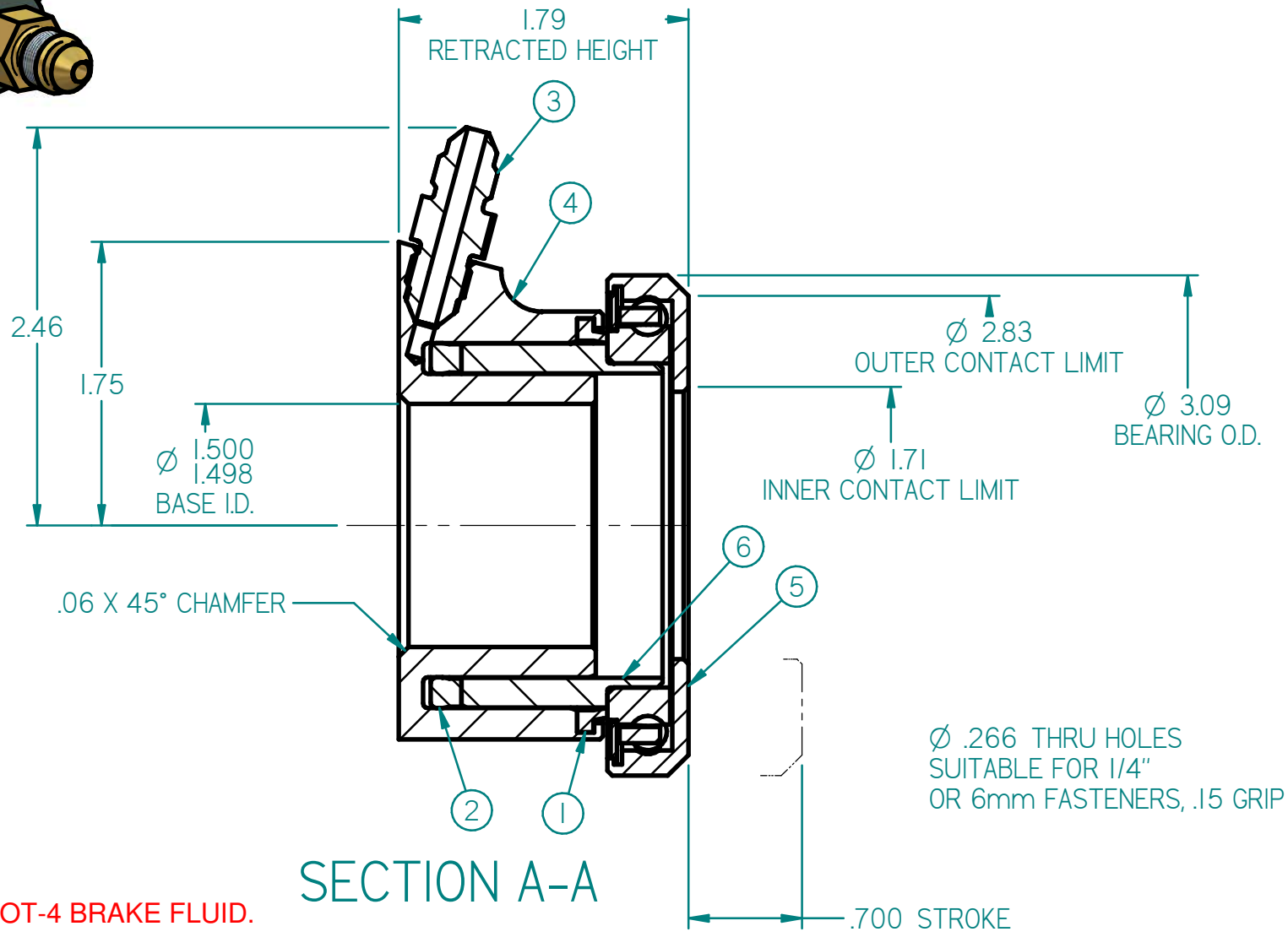

INSTALLATION NOTES:

1. USE ONLY WITH DOT-3 OR DOT-4 BRAKE FLUID.
2. NO INTERNAL TRAVEL LIMITER. MUST BE USED WITH CLUTCH PEDAL STOP.
3. SEAL REBUILD KIT = 62-905.
4. SEAL INSTALLATION TOOL = 96-002.
5. HYDRAULIC AREA = 1.215 SQ IN.
6. EITHER PORT MAY BE USED FOR FEED OR BLEED.
7. ORIENTATE BLEED PORT TO WITHIN 10 DEGREES OF TOP CENTER TO FACILITATE BLEEDING PROCESS.
8. BOTH PORTS 3/8-24 X .28 THREAD DEPTH.

TILTON ENGINEERING, INC. FAX 805/688-2745
 25 EASY STREET, P.O. BOX 1787, BUELLTON, CA 93427 805/688-2353

**TITLE: HYDRAULIC RELEASE BEARING ASSEMBLY
 FLAT FACED BEARING, UNIVERSAL BASE**

DRAWN BY WAHL	CHKD LUND	SCALE 1:1	SIZE B	DWG 5602	REV A
P/N 60-8100	DATE 03/20/2012	SHEET 1 OF 1			

This document contains proprietary information of TILTON ENGINEERING, INC., and its receipt or possession does not convey the rights to reproduce, disclose its contents, or to manufacture, use or sell anything it may describe. Reproduction, disclosure, or use without specific written authorization of TILTON ENGINEERING INC. is strictly forbidden.

