

Mitsubishi EVO Clutch Package

Note: This clutch package is designed for use with the 5-speed (non-MR) transmission only.

DESCRIPTION

Tilton's Mitsubishi EVO clutch packages are designed to offer increased torque capacity and reduced rotating mass. In addition, these clutch packages include a concentric hydraulic release bearing assembly that eliminates the stock external slave cylinder and related linkage. The clutch provides high torque capacity that enables you to "turn up the boost" while it's reduced rotating mass results in increased horsepower to the wheels. The hydraulic release bearing self-adjusts for clutch wear and provides great pedal feel. These clutch packages have been designed to be as "bolt-in" as possible, retaining the stock 5/8" bore master cylinder to provide efficient and comfortable clutch modulation.

Note: This instruction sheet is designed to supplement the general instructions sheets supplied with the individual components of the clutch package.

INSTALLATION

FLYWHEEL

1. Install flywheel onto engine. Torque OEM flywheel-to-crankshaft bolts to factory specification.

Note: The stock flywheel was not designed to accept an input shaft pilot bearing. We have designed our flywheel to accept a pilot bearing (NTN part# 6202LLU) to support the transmission's input shaft in high horsepower applications. If you choose to use a pilot bearing, you will also need to install a 15mm pilot extension on the input shaft.

CLUTCH DISCS

2. Install clutch discs into the clutch. For Carbon/Carbon clutches, orient the clutch hub as shown in **Diagram 1**. For Cerametallic clutches, align hubs as shown in **Diagram 2**. Be sure to align discs with an alignment tool or spare input shaft.

CLUTCH

3. Mount clutch onto the flywheel with the supplied aircraft grade hardware. Torque hardware to **18 lb-ft** using oil or Loctite. The tips of the spring fingers should taper slightly towards the transmission. The spring must not be inverted.
4. Test fit the transmission to the engine to confirm that there is no interference between the clutch's spring retaining hardware and the inside of the transmission case. There should be **.075"** of clearance, but due to variations in transmission castings the clearance may be decreased. If there is interference, you may have to grind the tips of the spring retaining screws to be flush with the nuts and/or grind some material from the transmission case.

Diagram 1

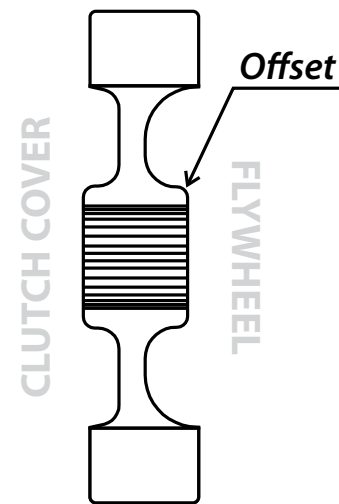
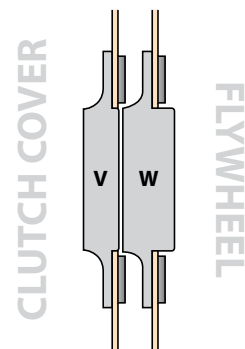

Diagram 2



V = Solid, 8 rivet, outer (.375" thick)

W = Solid, 8 rivet, outer (.550" thick)

INSTALLATION: HYDRAULIC RELEASE BEARING ASSEMBLY

1. Remove the existing Original Equipment (OE) slave cylinder, fork arm and release bearing from the transmission.

Note: To remove the release bearing unit you must pry a plug from the transmission case and remove the fork pin.

2. Remove the pilot tube from the transmission. Check the input shaft seal and replace if necessary. Clean the bearing retainer/pilot tube surface and bolt holes.
3. Install the provided hydraulic release bearing mount adapter (P/N 62-9900), positioning the hydraulic release bearing's mounting holes so that they are parallel to the ground as shown in Diagram 3. The adapter must sit flush on the mounting surface. Install the four (4) M6X1X14 flat head screws that are provided.
4. Before installing the hydraulic release bearing (P/N 61-9002 or 61-9012), route the supplied AN3 steel braided line to exit the transmission case without any sharp bends or kinks. If necessary, remove the rubber boot vent that is located at the upper left of the input shaft to create a convenient hole in the transmission case. Directions on how to trim and connect hydraulic lines are provided in the instructions that came with the 9000-Series hydraulic release bearing included in the package. Connect the supply line to the master cylinder with the banjo adapter and banjo bolt that is provided.
5. Thread the supplied fittings into the hydraulic release bearing. Install the hydraulic release bearing onto the mount adapter with the two (2) M6X1X10 cap head screws provided. Make sure that the highest port on the hydraulic release is used as the bleed line port, as shown in Diagram 3. Connect the supply and bleed lines to the hydraulic release bearing.
6. Remove the "helper/over center" spring from the clutch pedal assembly as shown in Diagram 4. This spring is designed to help overcome the resistance of the stock clutch's diaphragm spring, making clutch disengagement easier (less pedal effort). This spring is not needed for use with the Tilton clutch package, due to the supplied hydraulic release bearing assembly.
7. Install the pedal stop (P/N 72-008) that is included in your clutch kit using the instructions below.

CLUTCH PEDAL STOP

A positive clutch pedal stop must be used to prevent over-stroking the hydraulic release bearing piston and the clutch. For access reasons, in many cars it is not easy to determine how far the master cylinder is being stroked.

The method listed below provides a very effective method for adjusting the pedal stop:

1. Lift the drive wheels off the ground and support the car on jack stands.
2. With the engine off, place the gearbox in first gear and have someone attempt to rotate the drive wheels.
3. Depress the clutch pedal slowly until the clutch disengages and the drive wheels can be rotated.
4. Adjust pedal stop to allow another 1/4" of pedal travel. This should provide clean release of the clutch. Do not stroke the pedal any further than this point throughout this procedure, otherwise you will over-stroke the clutch.

Diagram 3

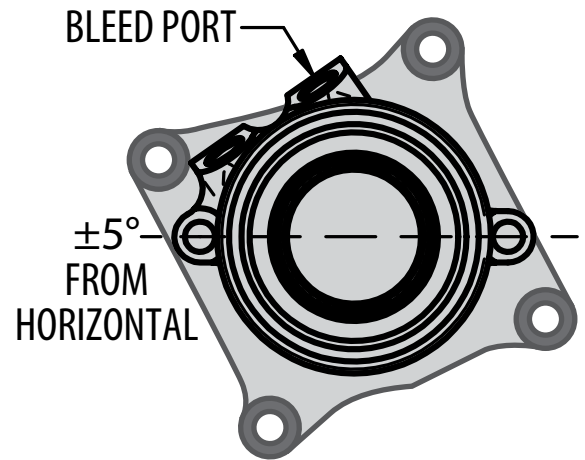

Diagram 4

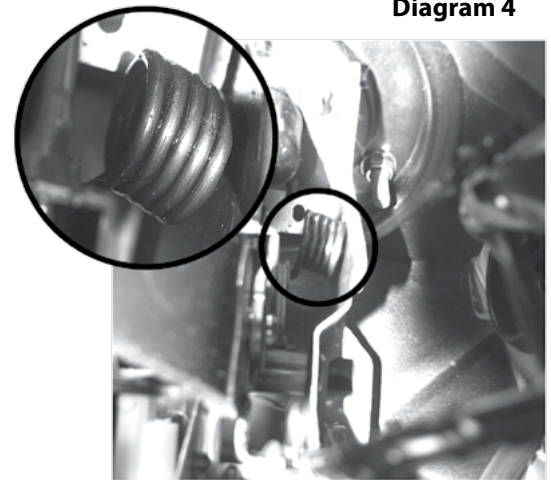

Diagram 5

