

REV	ECN	DATE	BY	CHANGE OR ADDITION

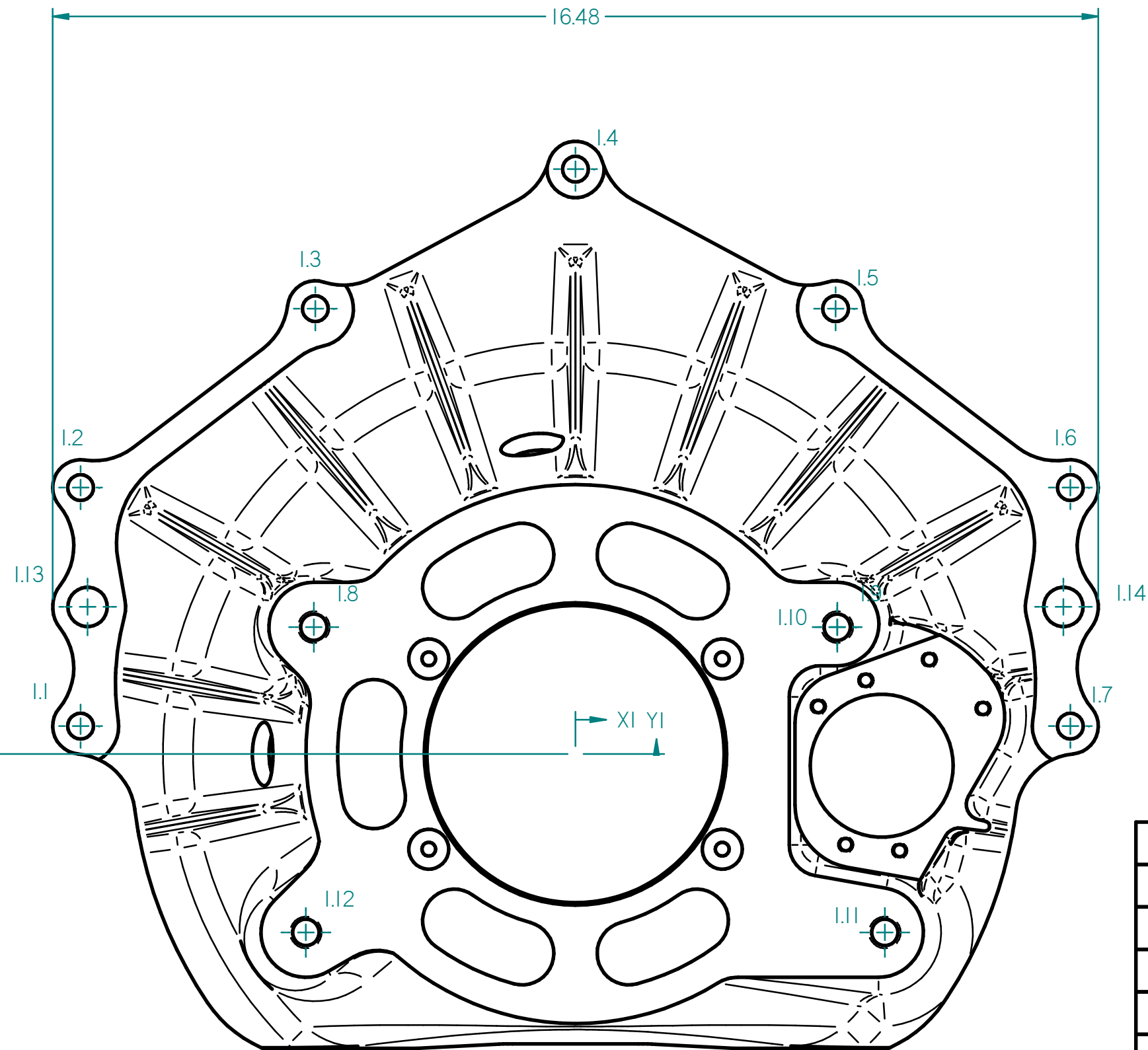
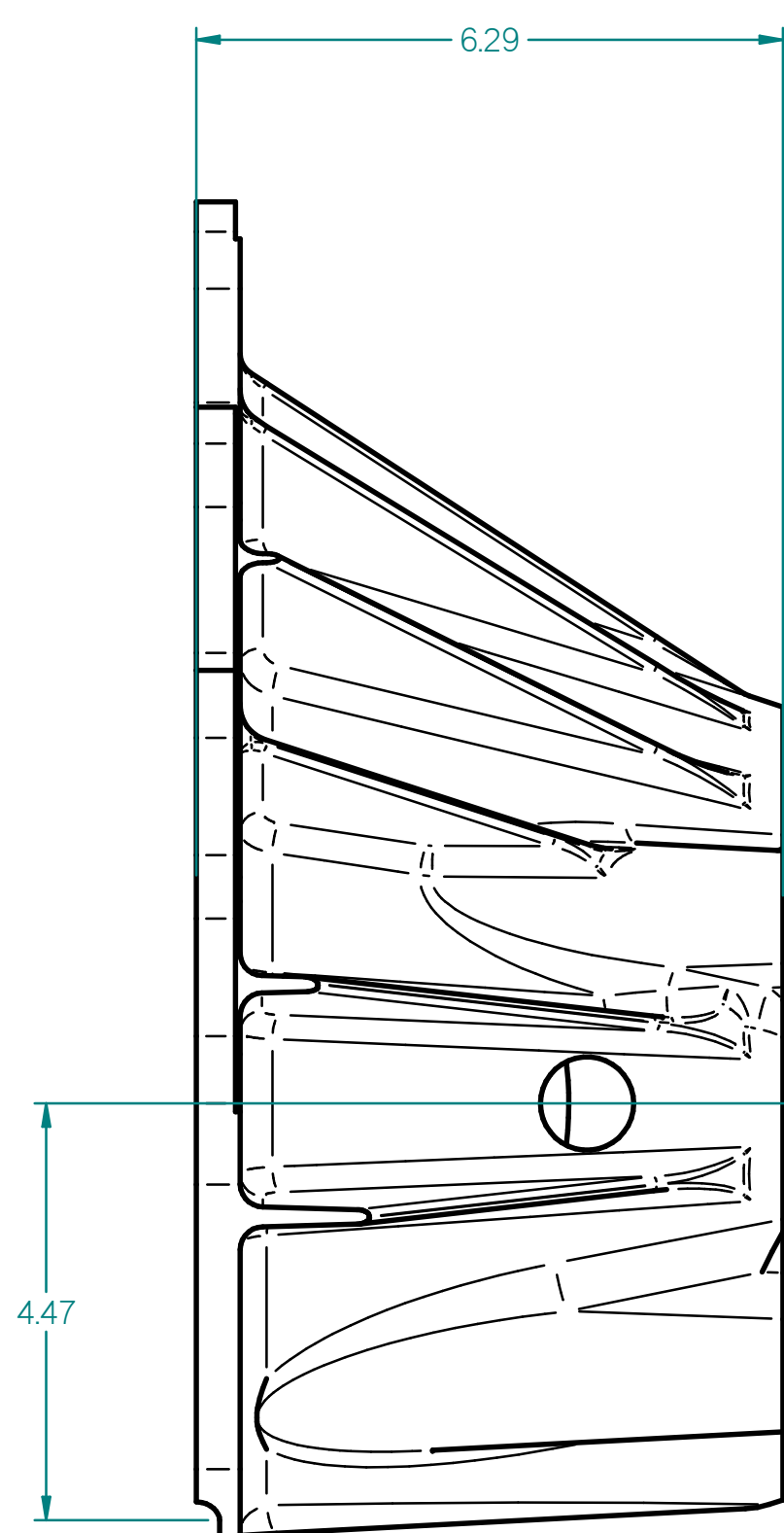

Hole Table		
Hole	X	Y
I.1	-7.800	.440
I.2	-7.800	4.200
I.3	-4.100	7.020
I.4	.000	9.220
I.5	4.100	7.020
I.6	7.800	4.200
I.7	7.800	.440
I.8	-4.125	2.000
I.9	4.125	2.000
I.10	4.125	2.000
I.11	4.875	-2.812
I.12	-4.250	-2.812
I.13	-7.690	2.320
I.14	7.690	2.320

TOLERANCES: UNLESS SPECIFIED OTHERWISE	
.X ±	.020
.XX ±	.010
.XXX ±	.005
FRACT ±	1/32
ANGLE ±	1/2°
CONC(TIR)	.005

DRILL HOLES	
.013-.040:	+ .001/- .001
.041-.130:	+ .002/- .001
.131-.229:	+ .003/- .001
.230-.500:	+ .004/- .001
.501-.750:	+ .005/- .001
.751-1.000:	+ .007/- .001

MAT'L	
SPEC	
COND	
HARD	
FINISH	
SPEC	

TILTON ENGINEERING, INC.
25 EASY STREET, P.O. BOX 1787, BUELLTON, CA 93427 805/688-2353

FAX 805/688-2745

TITLE: **BELLOUSING, CHEVROLET V8**
CUSTOMER DRAWING

DRAWN BY WAHL	CHKD	SCALE 1:2	SIZE C	DWG N/A	REV NC
P/N 52-601	DATE 07/10/2012	SHEET 1 OF 1			

"This document contains proprietary information of TILTON ENGINEERING, INC., and its receipt or possession does not convey the rights to reproduce, disclose its contents, or to manufacture, use or sell anything it may describe. Reproduction, disclosure, or use without specific written authorization of TILTON ENGINEERING, INC. is strictly forbidden."

tiltonENGINEERING