

REV	ECN	DATE	BY	CHANGE OR ADDITION
-----	-----	------	----	--------------------

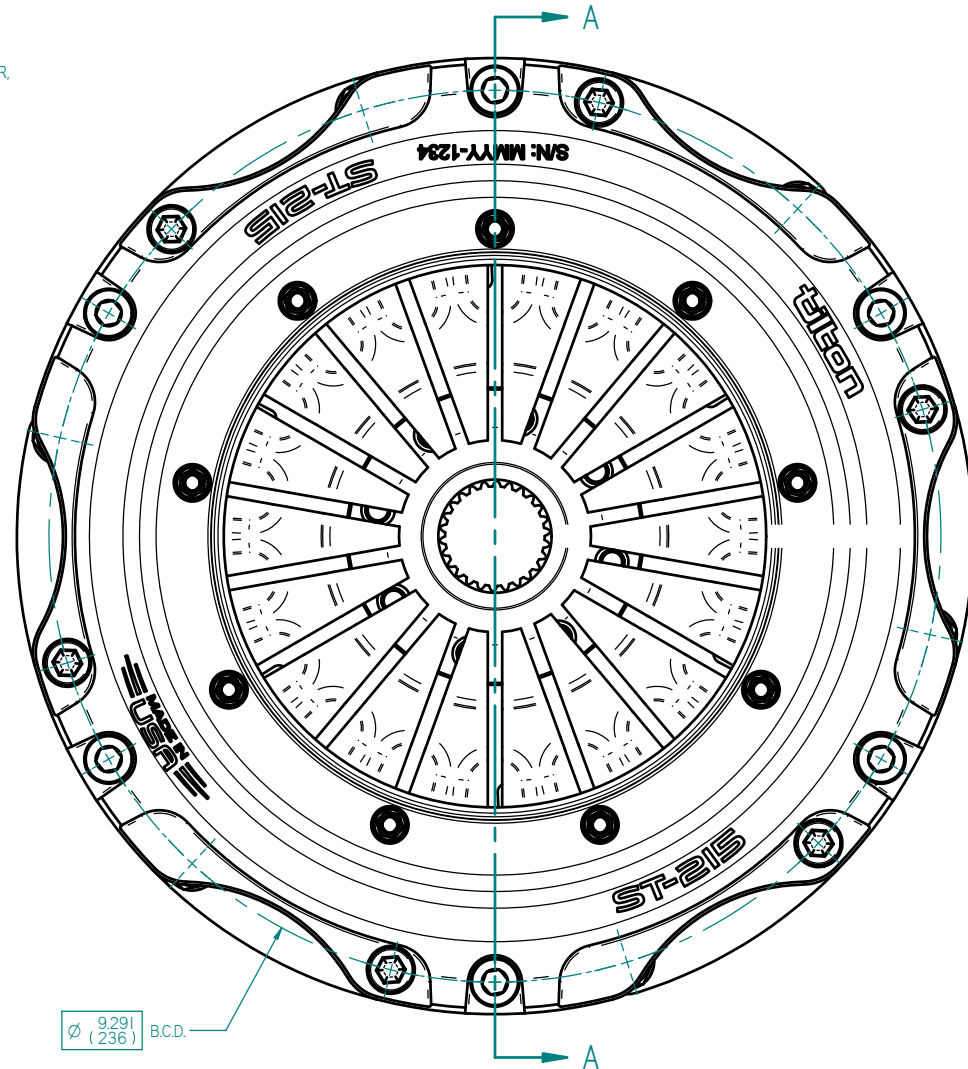
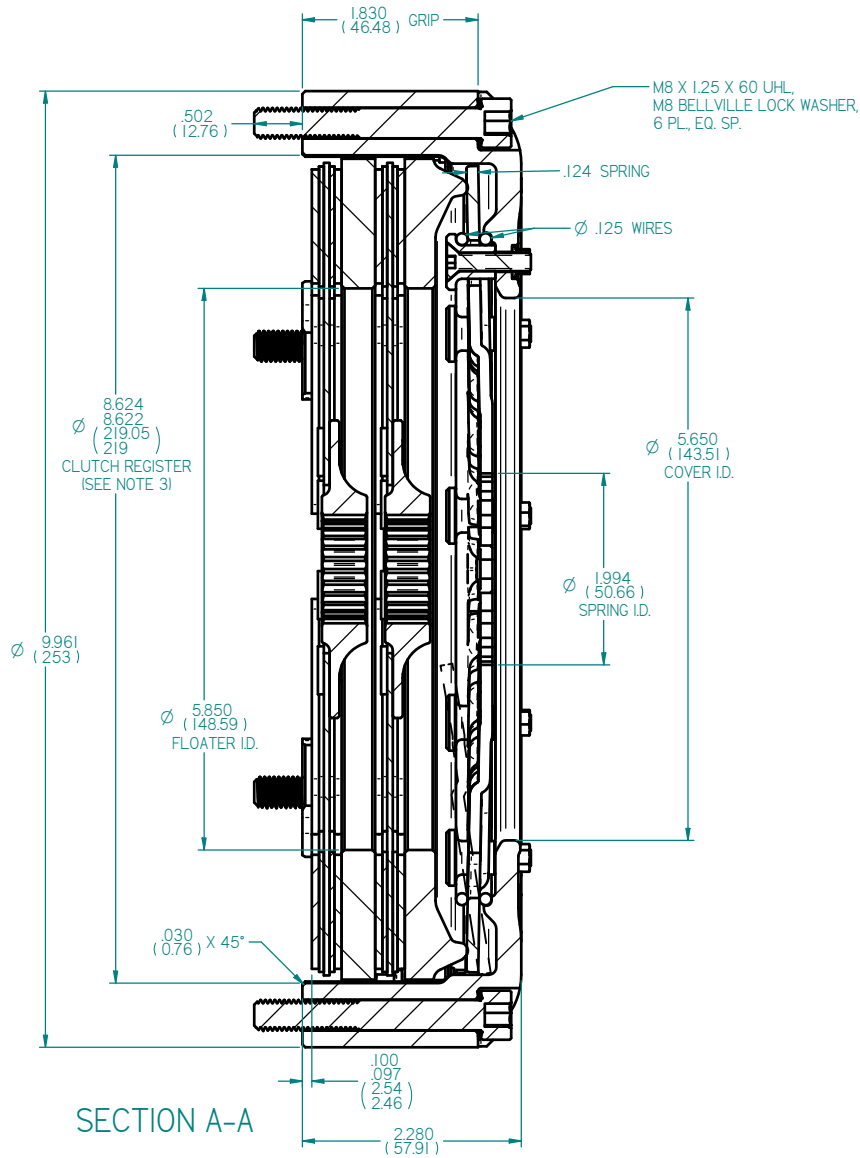
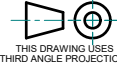

- NOTES:**
1. DIMENSIONS AND TOLERANCES PER ASME Y14.5 - 2009
 2. UNLESS OTHERWISE SPECIFIED, ALL DIMENSIONS ARE IN INCHES. MILLIMETERS SHOWN IN ().
 3. RECOMMENDED FLYWHEEL REGISTER 8.622"/8.620" (219mm/218.95mm).

TILTON ENGINEERING, INC. 25 EASY STREET, P.O. BOX 1787, BUELLTON, CA 93427 PHONE: 805/688-2353 FAX: 805/688-2745 WWW.TILTONRACING.COM				 <small>THIS DRAWING USES THIRD ANGLE PROJECTION</small>	
TITLE: CLUTCH INSTALLATION DRAWING ST-215 (215mm STRAP DRIVE), TWIN DISC, CERAMETALLIC, RIGID HUBS					
DRAWN BY WAHL P/N 68-602UG-36	CHKD DATE 7/13/2023	SCALE 1:1 SHEET 1 OF 1	SIZE C	DWG 7929	REV NC

TILTON ENGINEERING INC.

This document contains proprietary information of TILTON ENGINEERING, INC. and its receipt or possession does not convey the rights to reproduce, disclose its contents, or to manufacture, use or sell anything it may describe. Reproduction, disclosure, or use without specific written authorization of TILTON ENGINEERING, INC. is strictly forbidden.