

REV	ECN	DATE	BY	CHANGE OR ADDITION
NC		11/2/2018	LUND	INITIAL RELEASE

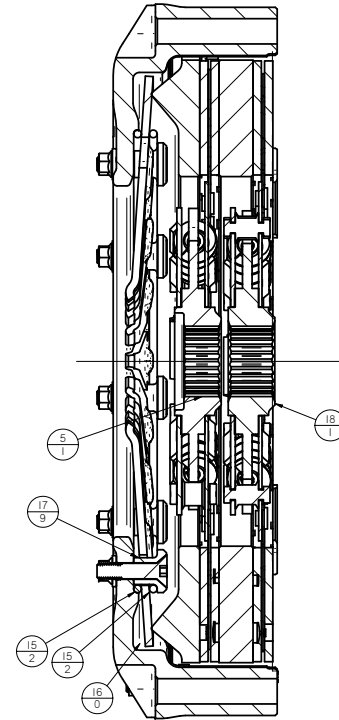

SECTION A-A

ITEM #	PART #	DESCRIPTION	QTY
1	69-120-2S	CLUTCH COVER, 246mm TWIN DISC CLUTCH	1
2'	69-125	DRIVE STRAP, 246mm TWIN DISC CLUTCH	18
3	69-119S	FLOATER PLATE, 246mm TWIN DISC CLUTCH	1
4	69-118LHR	PRESSURE PLATE, 246mm TWIN DISC CLUTCH	1
5	64246-5-S-36	DISC, FRICTION ASSEMBLY, 246MM, CLUTCH SIDE	1
6	NAS6205-5	BOLT, AIRCRAFT, 5/16-24 X .75	6
7	AN960-516	WASHER/FLAT AIRCRAFT FOR 5/16 BOLT	12
8	MS21042-5	THIN LOCK NUT 5/16-24	12
9	AN5-7A	HEX BOLT, AIRCRAFT, 5/16-24X.969	3
10	AN5-6A	HEX BOLT, AIRCRAFT, 5/16-24X.844	3
11	AN960-516L	WASHER/FLAT AIRCRAFT, THIN, FOR 5/16 BOLT	12
12	AN960-416	AN960-416 1/4" WASHER	9
13	MS21042-4	LOCK NUT, KAYNAR, 1/4-28 UNF	9
14	1/4-28 X 1.125 FHCS ZP	BOLT, 1/4-28 X 1.125L, FHCS, ZP	9
15	69-102	PIVOT WIRE, 246mm TWIN DISC CLUTCH	2
17	69-103	SLEEVE, FLANGE HEAD, 1/4 ID	9
18	64246-5M-S-36	DISC, FRICTION ASSEMBLY, 246MM, FLYWHEEL SIDE	1

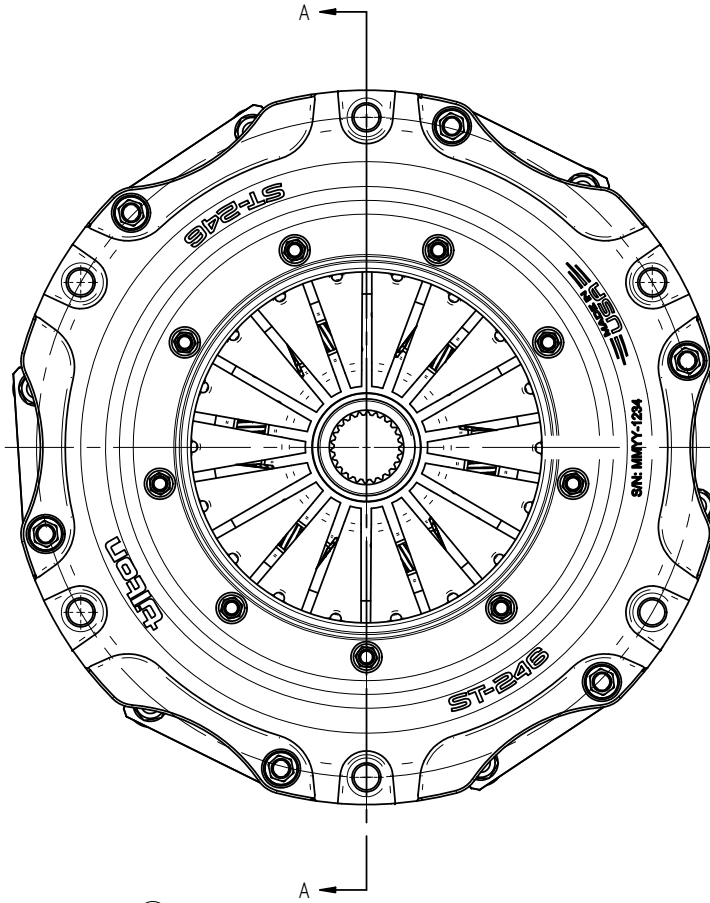
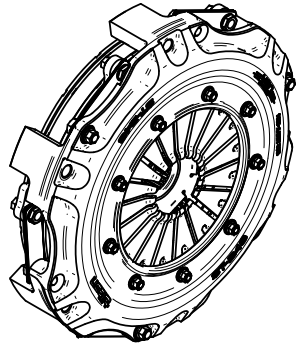
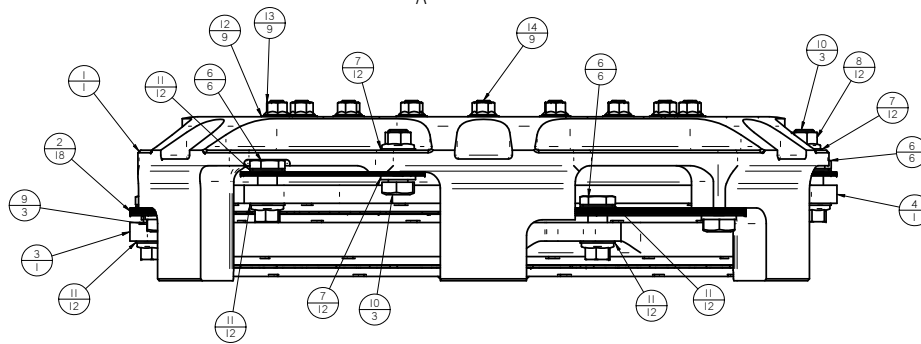

NOTES:
 1. DIMENSIONS AND TOLERANCES PER ASME Y14.5 - 2009
 2. UNLESS OTHERWISE SPECIFIED, ALL DIMENSIONS ARE IN INCHES.
 3. SEE SHEET 2 FOR FASTENER LOCATION CLARIFICATION.

TILTON ENGINEERING, INC. (805) 688-2353 FAX (805) 688-2745
 25 EASY STREET P.O. BOX 1787 BUELLTON, CALIFORNIA 93427 USA

TITLE: CLUTCH ASSEMBLY		SCALE 1:1		DWG 6982	REV NC
DRN BY WAHL	CHKD LUND	DATE 11/2/2018	SHEET 1 OF 2		

This document contains proprietary information of TILTON ENGINEERING, INC., and its receipt or possession does not convey the rights to reproduce, disclose its contents, or to manufacture, use or sell anything it may describe. Reproduction, disclosure, or use without specific written authorization of TILTON ENGINEERING, INC. is strictly forbidden.

TILTON ENGINEERING

REV	ECN	DATE	BY	CHANGE OR ADDITION
-----	-----	------	----	--------------------

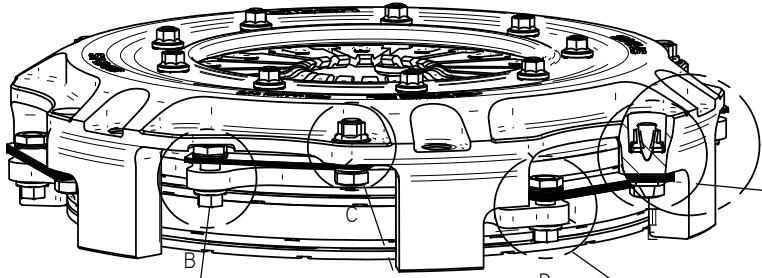

NAS6205-5
BOLT, AIRCRAFT, 5/16-24 X .75

AN960-516L
WASHER, FLAT, AIRCRAFT, THIN FOR 5/16 BOLT

69-118UHR
PRESSURE PLATE, 246mm TWIN DISC CLUTCH

AN960-516L
WASHER, FLAT, AIRCRAFT, THIN FOR 5/16 BOLT

MS21042-5
THIN LOCK NUT 5/16-24

DETAIL B

MS21042-5
THIN LOCK NUT 5/16-24

AN960-516
WASHER, FLAT, AIRCRAFT, FOR 5/16 BOLT

AN5-6A
HEX BOLT, AIRCRAFT, 5/16-24X.844

DETAIL C

AN960-516
WASHER, FLAT, AIRCRAFT, FOR 5/16 BOLT

MS21042-5
THIN LOCK NUT 5/16-24

AN960-516
WASHER, FLAT, AIRCRAFT, FOR 5/16 BOLT

AN960-516
WASHER, FLAT, AIRCRAFT, FOR 5/16 BOLT

AN5-7A
HEX BOLT, AIRCRAFT, 5/16-24X.969

DETAIL E

NAS6205-5
BOLT, AIRCRAFT, 5/16-24 X .75

AN960-516L
WASHER, FLAT, AIRCRAFT, THIN FOR 5/16 BOLT

69-119S
FLOATER PLATE, 246mm TWIN DISC CLUTCH

AN960-516L
WASHER, FLAT, AIRCRAFT, THIN FOR 5/16 BOLT

MS21042-5
THIN LOCK NUT 5/16-24

DETAIL D

TILTON ENGINEERING, INC. (805) 688-2353 FAX (805) 688-2745
25 EASY STREET P.O. BOX 1787 BUELLTON, CALIFORNIA 93427 USA

TITLE: CLUTCH ASSEMBLY
246mm, TWIN DISC CLUTCH, THICK FLOATER (SHOWN WITH SPRUNG HUB DISCS)

DRN BY	WAHL	CHKD	LUND	SCALE	1:1	DWG	6982	REV	NC
PIN	69-402UG	DATE	11/2/2018	SHEET	2 OF 2				

This document contains proprietary information of TILTON ENGINEERING, INC., and its receipt or possession does not convey the rights to reproduce, disclose its contents, or to manufacture, use or sell anything it may describe. Reproduction, disclosure, or use without specific written authorization of TILTON ENGINEERING, INC. is strictly forbidden.

TILTON ENGINEERING