

REV	ECN	DATE	BY	CHANGE OR ADDITION
NC		8/1/2023	WAHL	INITIAL RELEASE

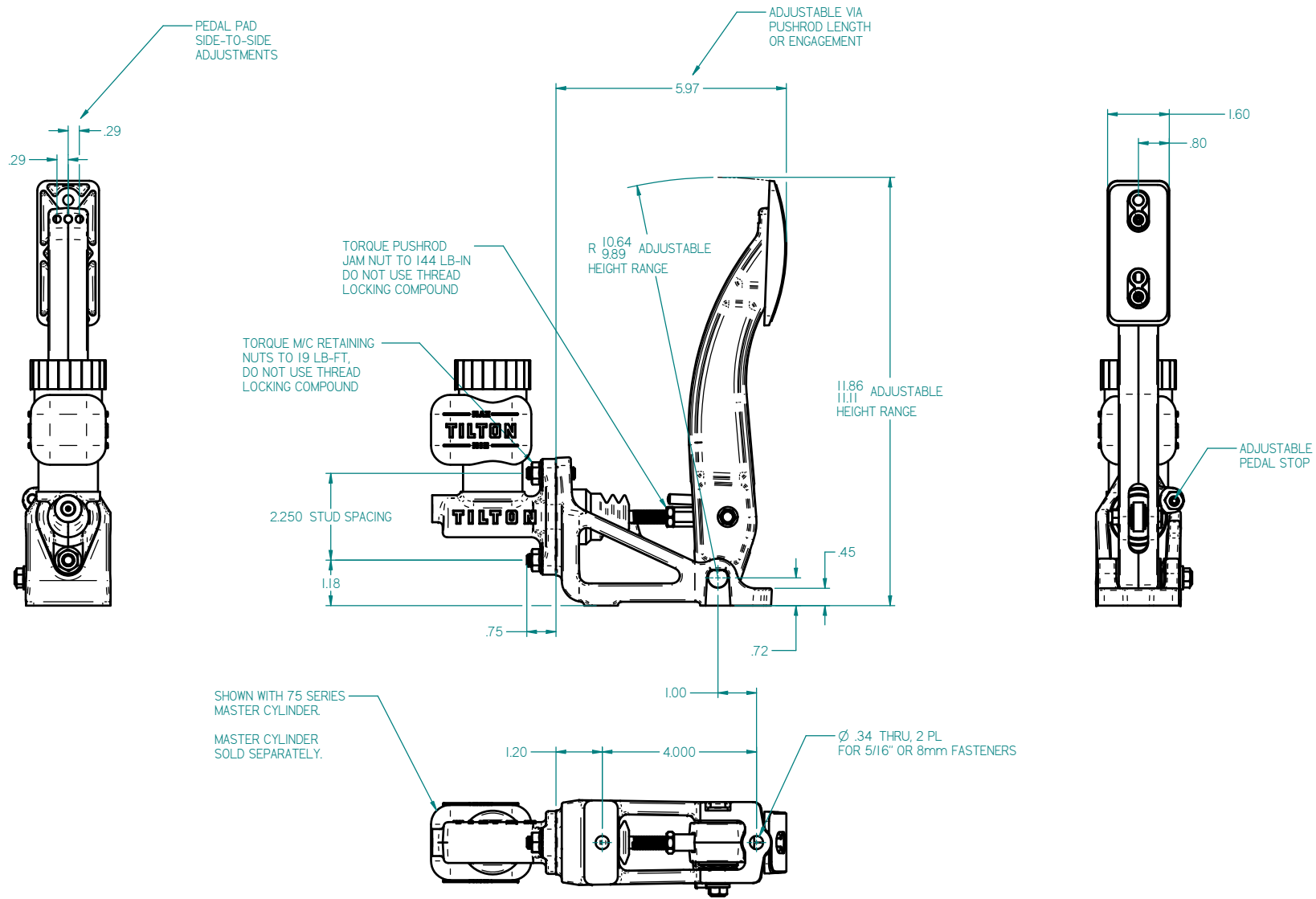

DO NOT EXCEED 3 DEGREES OF PUSHROD ANGULARITY DURING STROKE OF PEDALS. PREMATURE MASTER CYLINDER WEAR MAY OCCUR.

- NOTES:**
- DIMENSIONS AND TOLERANCES PER ASME Y14.5 - 2009
  - UNLESS OTHERWISE SPECIFIED, ALL DIMENSIONS ARE IN INCHES.

TILTON ENGINEERING, INC.  
 25 EASY STREET, P.O. BOX 1787, BUELLTON, CA 93427  
 PHONE: 805/688-2353 FAX: 805/688-2745 WWW.TILTONRACING.COM

THIS DRAWING USES THIRD ANGLE PROJECTION

**TITLE: INSTALLATION DRAWING  
CLUTCH PEDAL ASSEMBLY, FLOOR MOUNT**

DRAWN BY WAHL	CHKD DAHM	SCALE 1:2	SIZE C	DWG 7856	REV NC
P/N 72-613	DATE 8/1/2023	SHEET 1 OF 1			

**TILTON ENGINEERING**

This document contains proprietary information of TILTON ENGINEERING, INC. and its receipt or possession does not convey the rights to reproduce, disclose its contents, or to manufacture, use or sell anything it may describe. Reproduction, disclosure, or use without specific written authorization of TILTON ENGINEERING, INC. is strictly forbidden.