

2		1		
REV	ECN	DATE	BY	CHANGE OR ADDITION
NC		10/4/2022	WAHL	INITIAL RELEASE

This document contains proprietary information of TILTON ENGINEERING, INC. and its receipt or possession does not convey the right to reproduce, disseminate its contents, or to manufacture, use, sell, or otherwise dispose of any part thereof without specific written authorization of TILTON ENGINEERING, INC. is strictly forbidden.

TILTON ENGINEERING
INC.

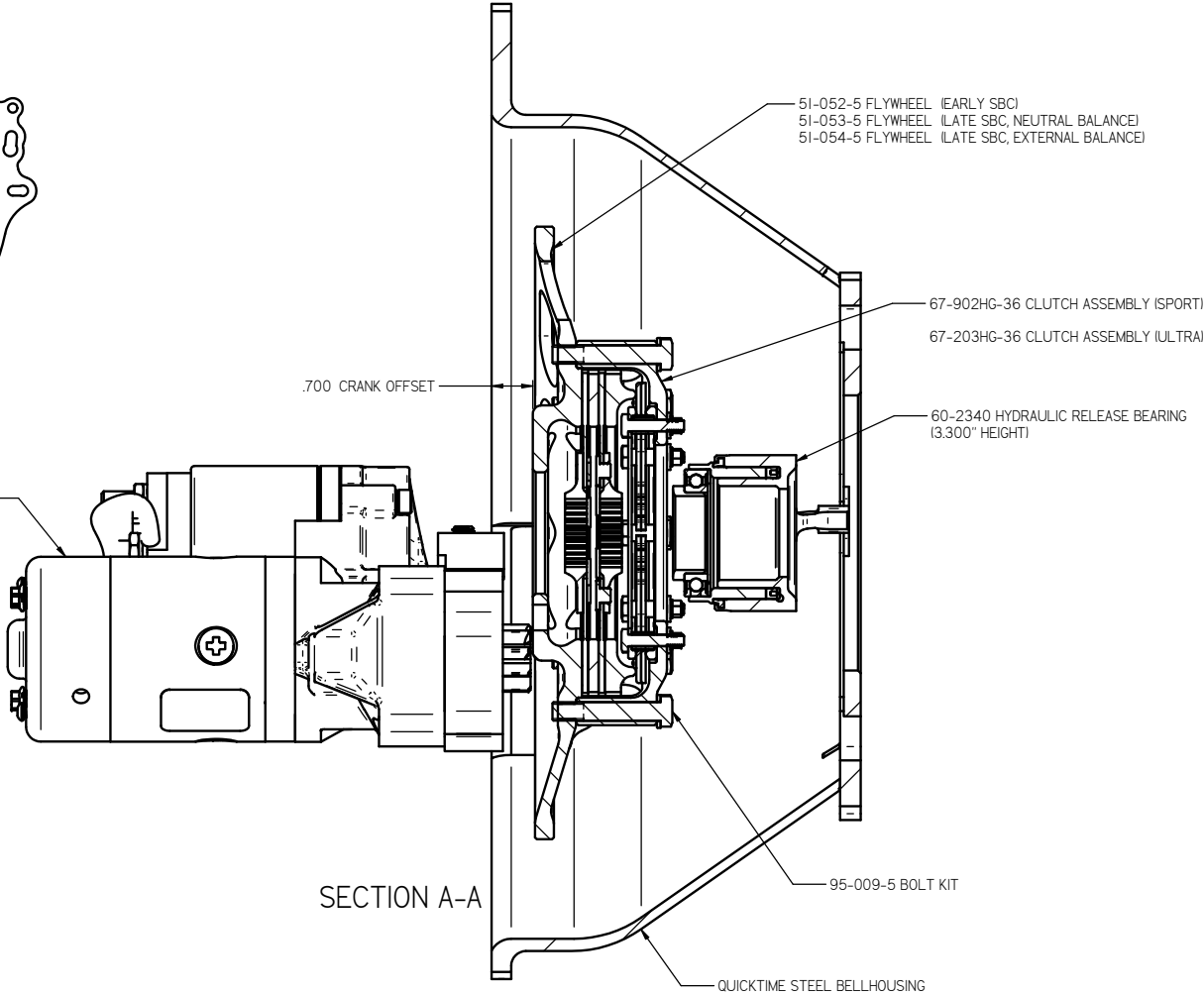
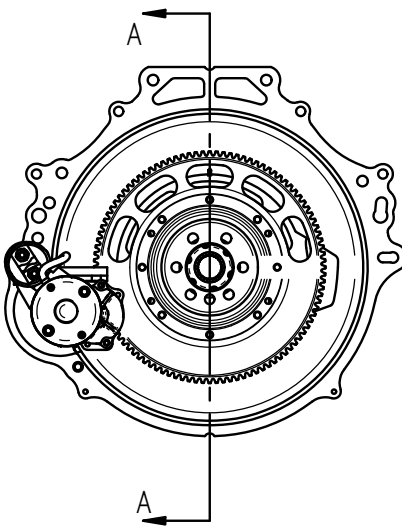

SECTION A-A

BH Kit	Description	Bellhousing	HRB	Starter	Flywheel	Clutch	FW Bolts	Clutch Bolts
53-81129	LMSC D/L KIT, CHEVY (E), 104T, 5.5" SPORT, 2 DISC, 26 SP, NO BELL	N/A	60-2340	54-40005	51-052-5	67-902HG-36	95-952-6	95-009-5
53-81629	LMSC D/L KIT, CHEVY (E), 104T, 5.5" ULTRA, 2 DISC, 26 SP, NO BELL	N/A	60-2340	54-40005	51-052-5	67-202HG-36	95-952-6	95-009-5
53-84129	LMSC D/L KIT, CHEVY (EX BAL CRATE), 104T, 5.5" SPORT, 2 DISC, 26 SP, NO BELL	N/A	60-2340	54-40005	51-054-5	67-902HG-36	95-952-6	95-009-5
53-84629	LMSC D/L KIT, CHEVY (EX BAL CRATE), 104T, 5.5" ULTRA, 2 DISC, 26 SP, NO BELL	N/A	60-2340	54-40005	51-054-5	67-202HG-36	95-952-6	95-009-5
53-86129	LMSC D/L KIT, CHEVY (LATE INT BAL), 104T, 5.5" SPORT, 2 DISC, 26 SP, NO BELL	N/A	60-2340	54-40005	51-053-5	67-902HG-36	95-952-6	95-009-5
53-86629	LMSC D/L KIT, CHEVY (LATE INT BAL), 104T, 5.5" ULTRA, 2 DISC, 26 SP, NO BELL	N/A	60-2340	54-40005	51-053-5	67-202HG-36	95-952-6	95-009-5

TILTON ENGINEERING, INC.
 25 EASY STREET, P.O. BOX 1787, BUELLTON, CA 93427
 PHONE: 805/688-2353 FAX: 805/688-2745 WWW.TILTONRACING.COM

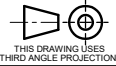

TITLE:			
DRIVELINE LAYOUT DRAWING			
CHEVY LATE MODEL STOCK, 104T/10P FLYWHEEL, 5.5" CLUTCH			
DRAWN BY	CHKD	SCALE	SIZE
WAHL	CHKD	2:3	C
P/N	DATE	SHEET	REV
SEE TABLE	10/4/2022	1 OF 1	7623 NC

NOTES:
 1. DIMENSIONS AND TOLERANCES PER ASME Y14.5 - 2009
 2. UNLESS OTHERWISE SPECIFIED, ALL DIMENSIONS ARE IN INCHES.