

ZONE	CHK'D	DATE	REV	ECN	CHANGE OR ADDITION
------	-------	------	-----	-----	--------------------

D

OUTLET PORT
3/8-24 UNF THREAD
FOR USE WITH
CRUSH WASHER FITTING

375
[9.52]
SPHERICAL BEARING WIDTH

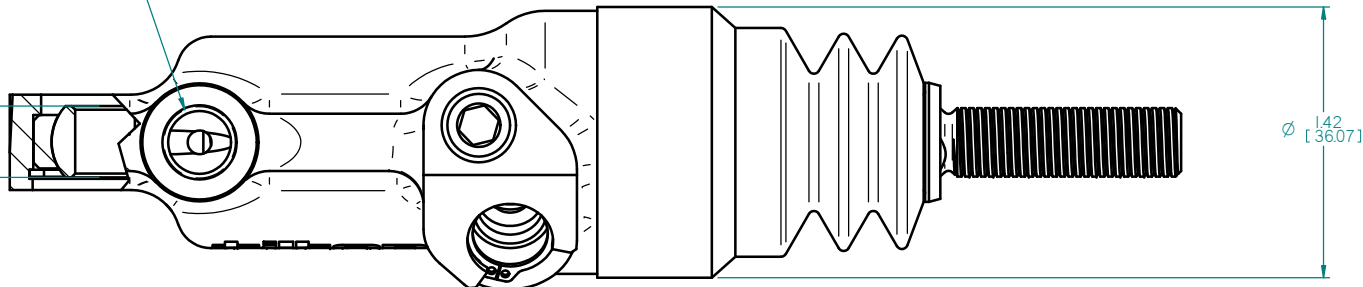

C

INLET PORT FOR TILTON SWIVEL LINES/FITTINGS.
79-521 LINE, 79-522, LINE, 79-523 90 DEG FITTINGS
SOLD SEPARATELY

1.96
[49.78]

Ø 312
[7.94] THRU
SPHERICAL BEARING

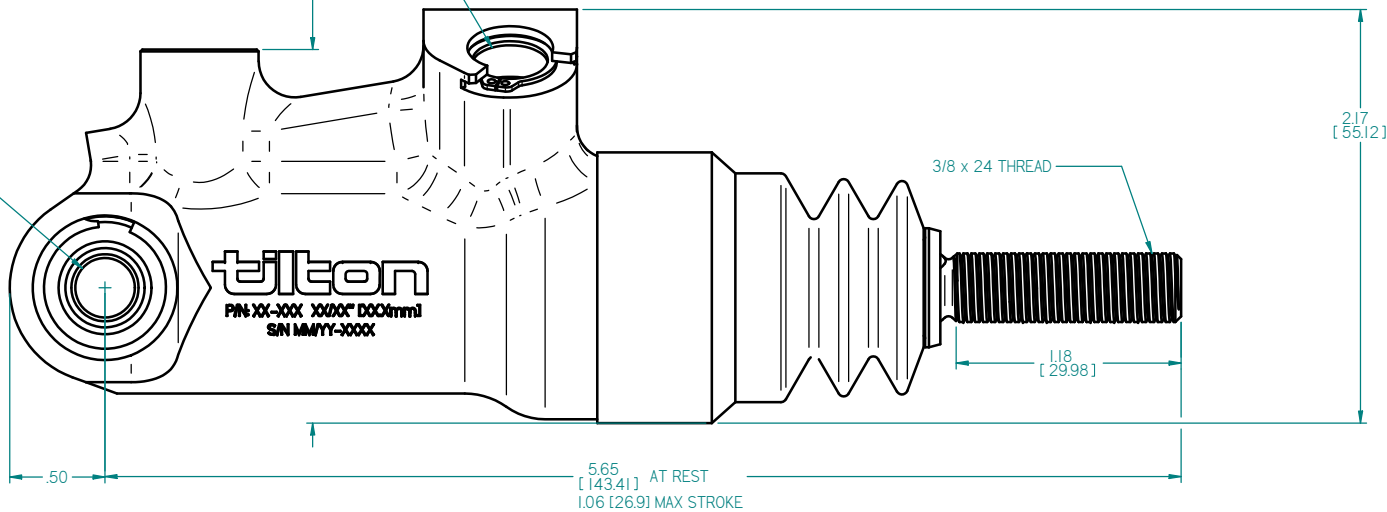

B

A

NOTES:

- 1. DIMENSIONS AND TOLERANCES PER ASME Y14.5 - 2009
- 2. UNLESS OTHERWISE SPECIFIED, ALL DIMENSIONS ARE IN INCHES [MM].

TILTON ENGINEERING, INC.			FAX 805/688-2745		
25 EASY STREET, P.O. BOX 1787, BUELLTON, CA 93427 805/688-2353					
TITLE: 79 SERIES M/C PRODUCTION ASSEMBLY DRAWING					
ALL BORE SIZES					
DRAWN BY	LUND	CHKD	WAHL	SCALE	2 : 1
P/N	SEE TABLE	DATE	8/10/2017	SHEET	2 OF 2
SIZE	C	DWG	6516	REV	B

*This document contains proprietary information of TILTON ENGINEERING, INC., and its receipt or possession does not convey the rights to reproduce, disclose its contents, or to manufacture, use or sell anything it may describe. Reproduction, disclosure, or use without specific written authorization of TILTON ENGINEERING, INC. is strictly forbidden.

TILTON ENGINEERING