

60-14xx Hydraulic Release Bearing

DESCRIPTION

Tilton's 60-14XX Hydraulic Release Bearing (also known as a concentric slave cylinder) is designed to be mounted either to the front of the gearbox or adapted to the bellhousing, depending on your application's design. This hydraulic bearing assembly uses a radius-faced bearing with a 54mm contact diameter that is intended to work with Tilton 8.5" clutches and some non-Tilton 4.5" - 7.25" clutches.

The hydraulic release bearing assembly is self-adjusting in that the bearing stays close to the clutch spring at all times. Although the spring changes position with clutch wear, there is no extra return spring that pulls the piston back all the way to the bottomed position. In this respect, the piston in the hydraulic bearing assembly works like the piston in a disc brake caliper, returning only as far as forced. For this reason, with a Tilton hydraulic release bearing the feel of the clutch does not change with clutch wear allowing the driver to make more consistent shifts.

PRIOR TO INSTALLATION

1. Both ports of the hydraulic release bearing are threaded 3/8-24 UNF x .28" deep with a 37° tapered seat and are suitable for use with standard AN-3 or JIC 37° fittings. Alternatively, the top of the port is machined flat for use with a crush washer (banjo fitting installations). Two AN-3 to AN-3 union fittings are supplied with the slave cylinder. If you choose to use banjo bolts instead, be sure that the bolt does not stick out past the bottom crush washer by more than .28".
2. Hydraulic hose is not included with this hydraulic release bearing. It is up to you to source high quality hose and a bleed fitting assembly. We recommend the use of PTFE lined stainless braided hose for the entire length of both the feed and bleed lines.
3. For most standard clutch pedal ratios, this hydraulic release bearing will work best with a 3/4" bore master cylinder.

INSTALLATION

Bearing clearance and mounting

1. Some applications may require you to cut the pilot tube off the gearbox input shaft bearing retainer. You may need to remove the bearing retainer from the gearbox to do this.
2. As received in the box, the bearing piston may not be fully retracted. You will need to compress it before taking any measurements. The small lip on the outside diameter of the piston is intended to bottom against the orange wiper seal.
3. Position the bearing assembly on the surface you wish to mount it so one port points directly up. This will be the port to which you attach the bleed line. Both ports are identical, so either one can be placed in the upward position. The other port will be attached to the supply line. Its orientation is not critical. Position the lines so they are clear of the clutch and flywheel.
4. Prepare the mounting surface to which the assembly will be attached. Three bolts (1/4" or 6 mm) hold the assembly in place. Accurate positioning should be done by utilizing the register found on the underside of the HRB body. This register should be on center with the input shaft within .010" (.25 mm).
5. Check the bearing clearance. A clutch assembly with worn friction discs will not provide accurate results, so make sure new friction discs are used when taking measurements. The bearing clearance must be in the range of .170"-.200" (see **Diagram 1**). If the clearance is less than this range, there will not be enough room to allow for the full wear range of the clutch since clearance reduces with clutch wear.



Diagram 1

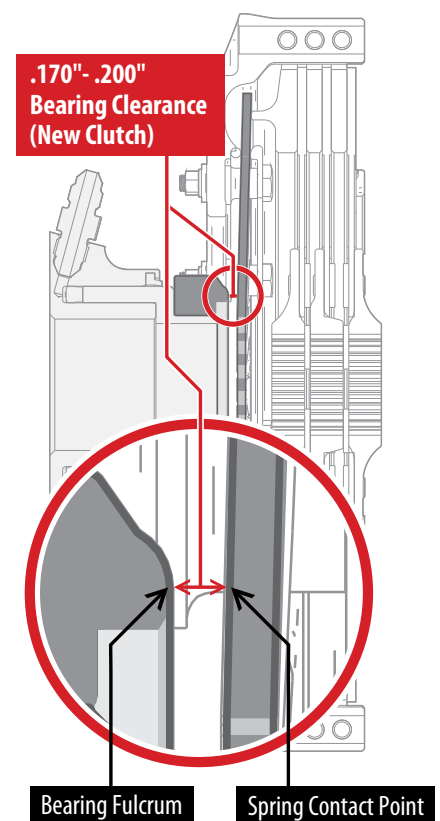

Hydraulic lines and fittings

Install the two supplied union fittings and tighten. These fittings are made to seal on the tapered section and not the threads. Do not use pipe tape or other sealants.

Install the (customer-supplied) hydraulic lines and bleed fitting assembly, routing both of the lines clear of the exhaust system, oil lines and other heat sources.

MASTER CYLINDER PRIMING

1. Fill the master cylinder with brake fluid. Use a DOT 3, DOT 4 or other non-silicone based fluid.
Avoid DOT 5 (silicone based) fluids since they are not compatible with the seals.
2. Open the bleed fitting (if equipped) at the master cylinder while the line port is closed.
3. Gently depress the clutch pedal, close the bleed screw and release the clutch pedal.
4. Repeat Steps 1 and 2 until fluid free of air bubbles emerges.

Do not stroke a Tilton master cylinder more than 1".

HYDRAULIC RELEASE BEARING BLEEDING

1. Fill the master cylinder reservoir with DOT 3 or DOT 4 brake fluid.
2. Apply approximately 3 lbs of force on the clutch pedal. You want enough force to hold the bearing out against the clutch diaphragm spring, but not enough to actually move the spring.
3. Open the bleed screw that is attached to the bleed line on the hydraulic release bearing.
4. Completely stroke the pedal.
5. Close the bleed screw.
6. Let the pedal return to its relaxed position and wait a few seconds.
7. Repeat Steps 2 through 6 while keeping an eye on the fluid level until all air is removed from the system.

Note: You do not want to stroke the clutch during the bleeding process. All you are trying to do at this point is get all of the air out of the system.

Do not stroke the clutch until the pedal stop is set!

CLUTCH PEDAL STOP

A positive clutch pedal stop must be used to prevent over-stroking the hydraulic release bearing piston and the clutch. For access reasons, in many cars it is not easy to determine how far the master cylinder is being stroked. The method listed below provides a very effective method for adjusting the pedal stop:

1. Lift the drive wheels off the ground and support the car on jack stands.
2. With the engine off, place the gearbox in first gear and have someone attempt to rotate the drive wheels.
3. Depress the clutch pedal slowly until the clutch disengages and the drive wheels can be rotated.
4. Adjust pedal stop to allow another 1/4" of pedal travel. This should provide clean release of the clutch. Do not stroke the pedal any further than this point throughout this procedure, otherwise you will over-stroke the clutch.

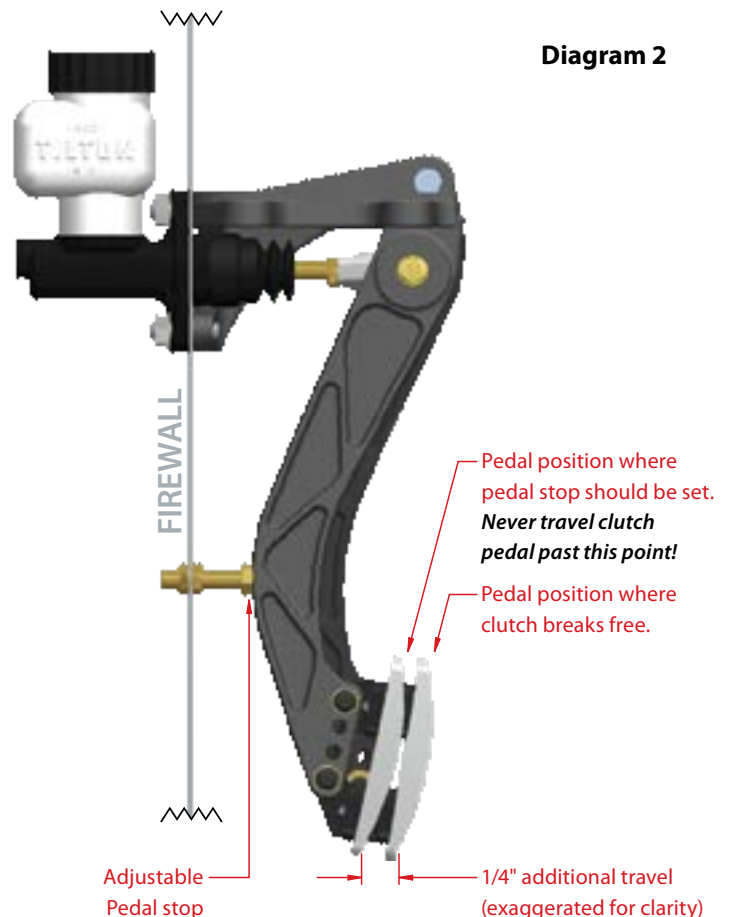

Scan to watch a video on Clutch Pedal Stop: How to Set a Clutch Pedal Stop or visit www.tiltonracing.com/technical/technical-videos/



MAINTENANCE

A few basic procedures will help to ensure that your hydraulic release assembly will provide a long and dependable life.

1. Spin the bearing race and check how it feels. If it has a higher than normal resistance or feels rough, replace the bearing.
2. The piston can be removed and replaced without breaking the hydraulic seal or requiring bleeding. Periodically, remove the piston and check for any scores in the bore or on the piston surface. Wipe the piston and orange dust wiper seal before reinstalling. You may find that the piston is not dry. This could be the rubber grease used when installing the new seal. Do not mistake this for brake fluid.
3. If the seal needs replacing, order Tilton's replacement seal kit (P/N 62-905). Instructions and the correct installation grease are included in the kit. We also recommend the use of a seal installation tool (P/N 96-002) to prevent damaging the seal during installation.

SERVICE INFORMATION

1. Contact Tilton's Repair Department (805-688-2353) and describe the problem or the service that is required.
2. If the bearing assembly needs to be sent in, a Returned Merchandise Authorization (RMA) number is required and will be provided by a Tilton representative.
3. Write the RMA number on the outside of the package and ship to:
Tilton Engineering
25 Easy Street
Buellton CA 93427

This document contains proprietary information of TILTON ENGINEERING, INC. and its subsidiaries or possession thereof. No disclosure or use without specific written authorization of TILTON ENGINEERING, INC. is strictly forbidden.



| ITEM | PART NUMBER | DESCRIPTION | QTY |
|------|-------------|----------------|-----|
| 1 | 62-1000 | HYDRAULIC BASE | 1 |
| 2 | SEE CHART | PISTON | 1 |
| 3 | 62-611 | BEARING, 54mm | 1 |
| 4 | 62-614 | SEAL | 1 |
| 5 | 62-617 | WIPER | 1 |
| 6 | 73-820 | FITTING, AN-3 | 2 |

| CHART OF AVAILABLE ASSEMBLIES | | |
|-------------------------------|---------|-----------|
| HEIGHT | ASSY PN | PISTON PN |
| 1.84" | 60-1400 | 62-6100 |
| 2.04" | 60-1420 | 62-6102 |

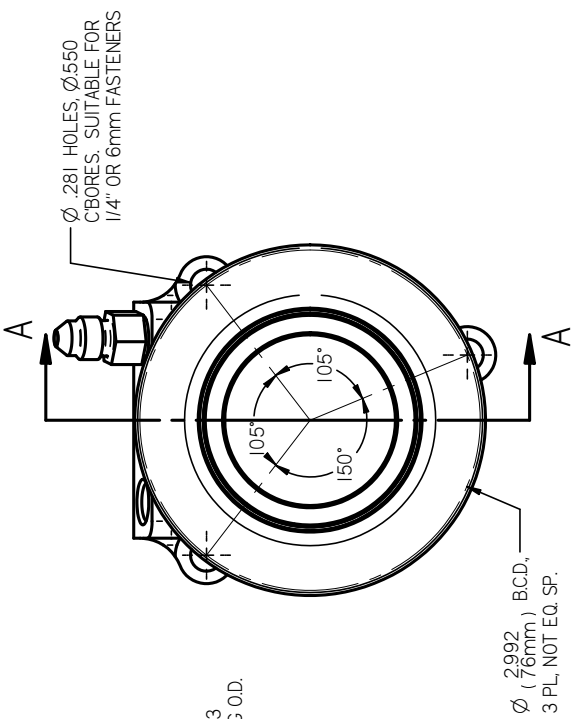
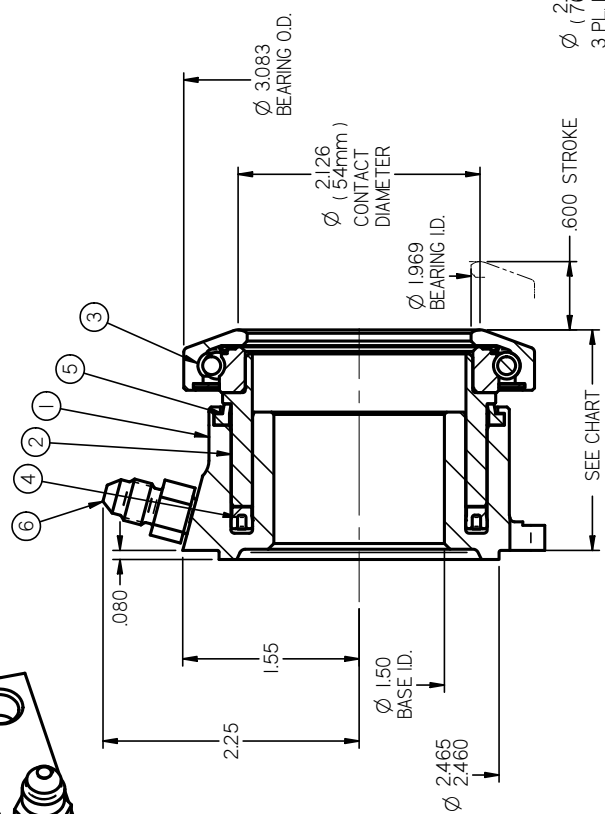
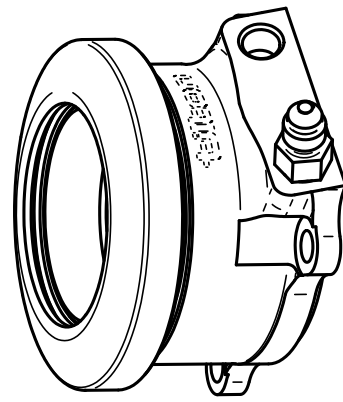

SECTION A-A

- INSTALLATION NOTES:**
1. USE ONLY WITH DOT-3 OR DOT-4 BRAKE FLUID.
 2. NO INTERNAL TRAVEL LIMITER. MUST BE USED WITH CLUTCH PEDAL STOP.
 3. SEAL REBUILD KIT = 62-905.
 4. SEAL INSTALLATION TOOL = 96-002.
 5. HYDRAULIC AREA = 1.215 SQ IN.
 6. EITHER PORT MAY BE USED FOR FEED OR BLEED.
 7. ORIENTATE BLEED PORT WITH 10 DEGREES OF TOP CENTER TO FACILITATE BLEEDING PROCESS.
 8. BOTH PORTS 3/8-24 UNF X .28 THREAD DEPTH.

TILTON ENGINEERING, INC.
 25 EASY STREET, P.O. BOX 1787, BUELLTON, CA 93427 805/688-2353
 FAX 805/688-2745

TITLE: HYDRAULIC RELEASE BEARING ASSEMBLY
54mm RADIUS FACED BEARING, SAAB 9000 MOUNTING

| | | | | | | | |
|----------|-----------|------|----------|-------|--------|-----|---------|
| DRAWN BY | WAHL | CHKD | SCALE | 1:1 | SIZE | DWG | REV |
| P/N | SEE CHART | DATE | 3/2/2021 | SHEET | 1 OF 1 | B | 7456 NC |